



Partition Stalls

Installation Instructions for Solid Plastic Partitions

☎ 646-453-4564

✉ info@partitionstalls.com

🌐 www.partitionstalls.com

SOLID PLASTIC PARTITIONS

Revised 2/26/22

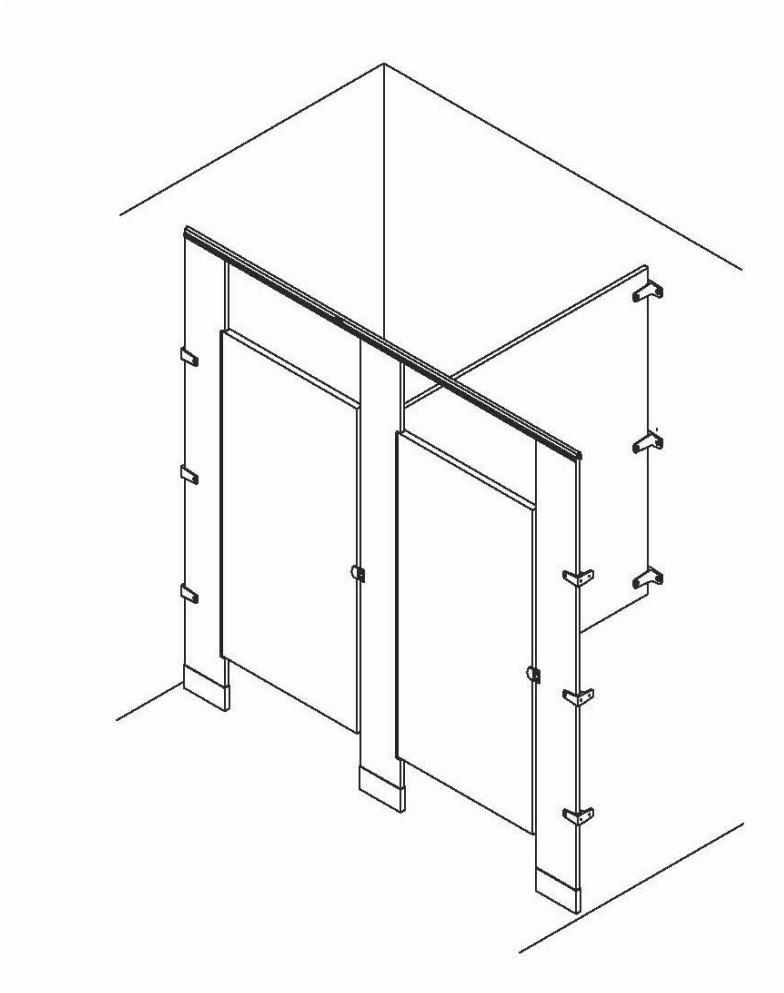

Thank you for choosing Global Partitions

This installation guide was designed to cover as many variations of hardware and mounting styles as possible, while also trying to keep it light and focused.

While all materials and standard mounting selections are present, in order to cover the numerous choices of hardware, we have presented each material with it's default hardware. Therefore, while each type is covered, it will be with it's most common mounting style (i.e. continuous brackets on ceiling-hung, piano hinges on Polymer, etc).

Please read all steps in their entirety before beginning actual install, as some field conditions and hardware combinations may require alternate installation.

Table of Contents

<u><i>Floor Anchored/Overhead Braced</i></u>	<u><i>Page</i></u>
Step 1,2,3.....	1
Step 3,4,5.....	2
Panel to Pilaster/Wall Two Ear Assembly.....	3
Panel to Pilaster/Wall One Ear Assembly.....	4
Pilaster/Wall One Ear Assembly.....	5
Pilaster/Panel Alcove Assembly.....	6
Door Hardware (Vault Hinge Inswing) Assembly.....	7
Door Hardware (Vault Hinge Outswing) Assembly.....	8
Door Hardware (8" Wrap Hinge Inswing) Assembly.....	9
Door Hardware (8" Wrap Hinge Outswing) Assembly.....	10
Door Hardware (Integral Hinge) Assembly.....	11
Door Hardware (Piano Hinge) Assembly.....	12
Headrail Assembly.....	13
Urinal Screen Assembly.....	14
 <u><i>Ceiling Anchored</i></u>	
Step 1,2,3.....	15
Step 3,4,5.....	16
Panel to Panel/Wall Assembly.....	17
Pilaster/Wall One Ear Assembly.....	18
Pilaster/Panel Alcove Assembly.....	19

Table of Contents

<u>Floor Anchored and Ceiling Anchored</u>	<u>Page</u>
Step 1,2,3.....	20
Step 3,4,5.....	21
Panel to Panel/Wall Assembly.....	22
Pilaster/Wall One Ear Assembly.....	23
Pilaster/Panel Alcove Assembly.....	24
 <u>Full Height Bracket Kits</u>	
Panel to Pilaster/Wall Assembly.....	25
Panel to Pilaster/Wall One Ear Assembly.....	26
 <u>Product Information</u>	
Care and Maintenance of Toilet Partitions.....	27

The Components for this project have been custom fabricated. They are guranteed with respect to manufacture and workmanship and were inspected at the factory.

Before beginning work, the units should be inspected. If damage occurred in transit, report immedicately to the freight company or other agencies that may have caused the damage.

STEP 1 LAYOUT

FLOOR ANCHORED/OVERHEAD BRACED

NOTE:FLOOR MUST BE CONCRETE

- Review the layout drawings and package lists that have accompanied this job.
- Before proceeding, confirm that backing of walls and floor is adequate to support secure mounting of the toilet compartment units.
- Establish and mark pilaster center line from back wall.
- Establish and mark panel center lines for wall brackets.
- Establish pilaster floor fastener locations from side wall according to shop drawings. (Note floor fasteners are located 1" from edge of pilaster.)
- Mark wall bracket holes using brackets as templates.

FIGURE 1

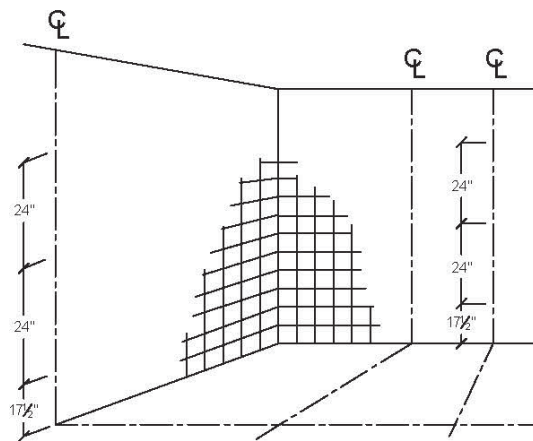

STEP 2 WALL BRACKETS AND FLOOR ANCHORS

- Drill holes for wall brackets and floor anchors of appropriate size for particular fastening devices supplied. Typically, 5/16" bit for walls, 1/4" bit for compartment thru-bolts, and 3/16" bit for floors. (Note: As site conditions and hardware combinations vary, an assortment of bit sizes are recommended.)
- Insert anchoring devices in walls and secure wall brackets.
- Attach the shoes to the concrete floor using the 1/4" concrete screws. (Note: The hole in the side of the shoe should be placed on the inside of the compartment.)
- Adjust the location of the shoes according to the door opening size and secure shoes to the floor.

FIGURE 2

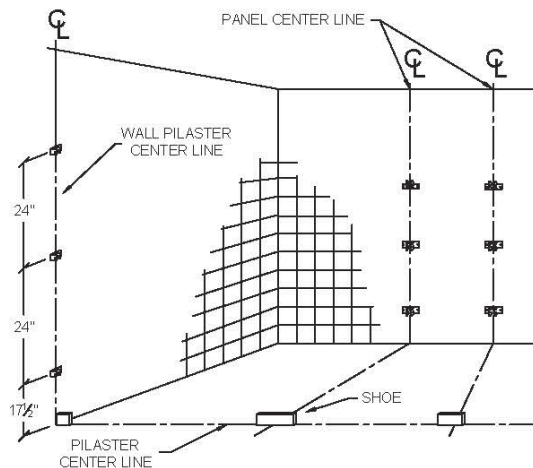

STEP 3 POSITION PANEL

- Place panel on a support, 14" above the floor.
- Set it into wall brackets, but do not fasten panel at this time.

NOTE: Metal heat-sink strip will be on bottom of panel

FIGURE 3

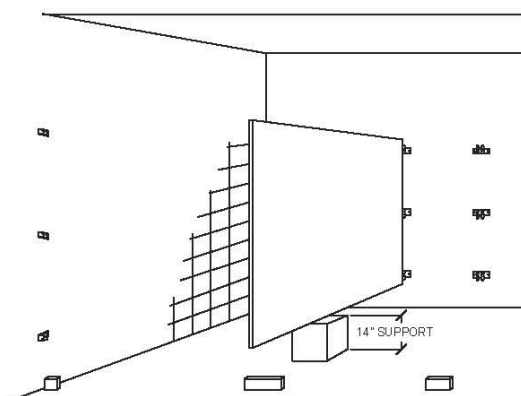

STEP 4 **PILASTER PREPARATION**

- A. Align brackets in position on rear of pilasters. Refer to layout drawings.
- B. Fasten brackets to pilaster with sheet metal screws.
- C. Pilasters at wall will not have U-brackets, but should be prepared for wall (and floor fastening) as required by compartment layout.

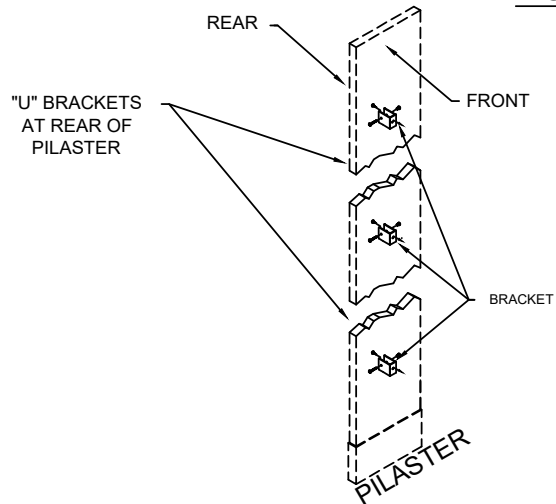
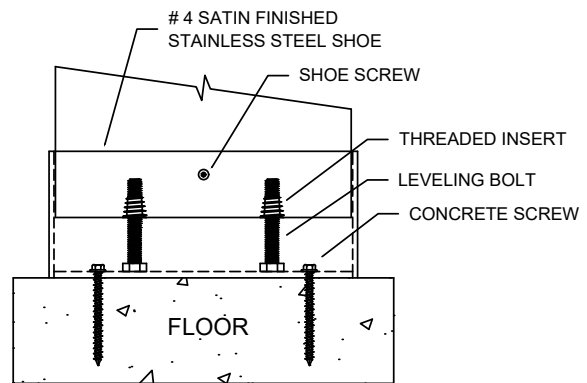

FIGURE 4

STEP 5 **INSTALL PILASTERS**

- A. Insert the leveling bolt into the threaded insert at the bottom of the pilaster.
- B. Insert the pilaster into the shoe.
- C. Level the top of all pilasters by adjusting the leveling bolt to desired position.

Note: To determine how far to insert the leveling bolt, find the highest point on the floor, and fully insert the bolt on the pilaster that will be mounted in that location. Adjust all other leveling bolts accordingly.



FLOOR MOUNTING DETAIL

FIGURE 5

STEP 6 **SECURING PILASTER/PANEL**

- A. Level the panel and adjust the gaps at either end.
- B. Secure the panel to the wall and pilaster using through bolts.
- C. Remove panel support device.
- D. Plumb each pilaster and secure with headrail. (See pg 13 for headrail detail.)
- E. Secure the pilaster to the shoe using shoe screws.

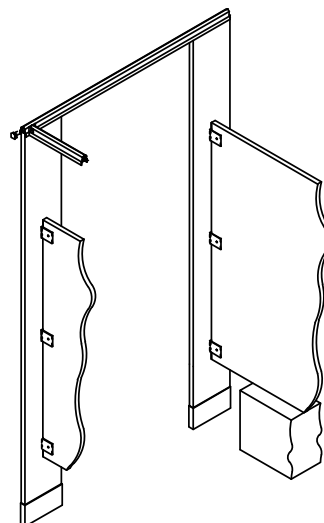









FIGURE 6

**FLOOR ANCHORED/OVERHEAD BRACED
PANEL TO PILASTER/WALL
TWO EAR ASSEMBLY
POLYMER**

Note: The tops of all pilasters must be level with one another prior to securing the pilaster to the panel.

- A. Level the panel and adjust the gaps at either end.
- B. Secure the panel to the wall using through bolts.
- C. Plumb the pilaster front to back
- D. Secure the pilaster to the panel using through bolts
- E. Remove panel support device.

Aluminum Panel Hardware Kit (P/N 8445020) Includes			
PART ID.		DESCRIPTION	QTY
1		Two Ear Alum. Bracket	(3)
2		Alum. "U" Bracket	(3)
3		Vandal Resistant 1" Step Bolt	(6)
4		Vandal Resistant 5/8" Barrel Nut	(6)
5		Vandal Resistant 2-1/2" Screw	(6)
6		Plastic Shield	(6)
7		Vandal Resistant 5/8" Screw	(3)

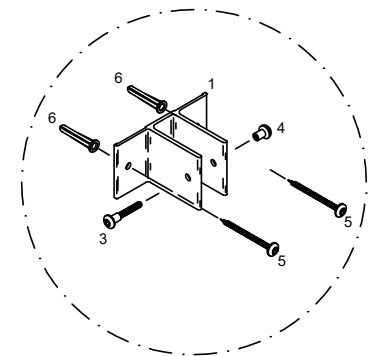
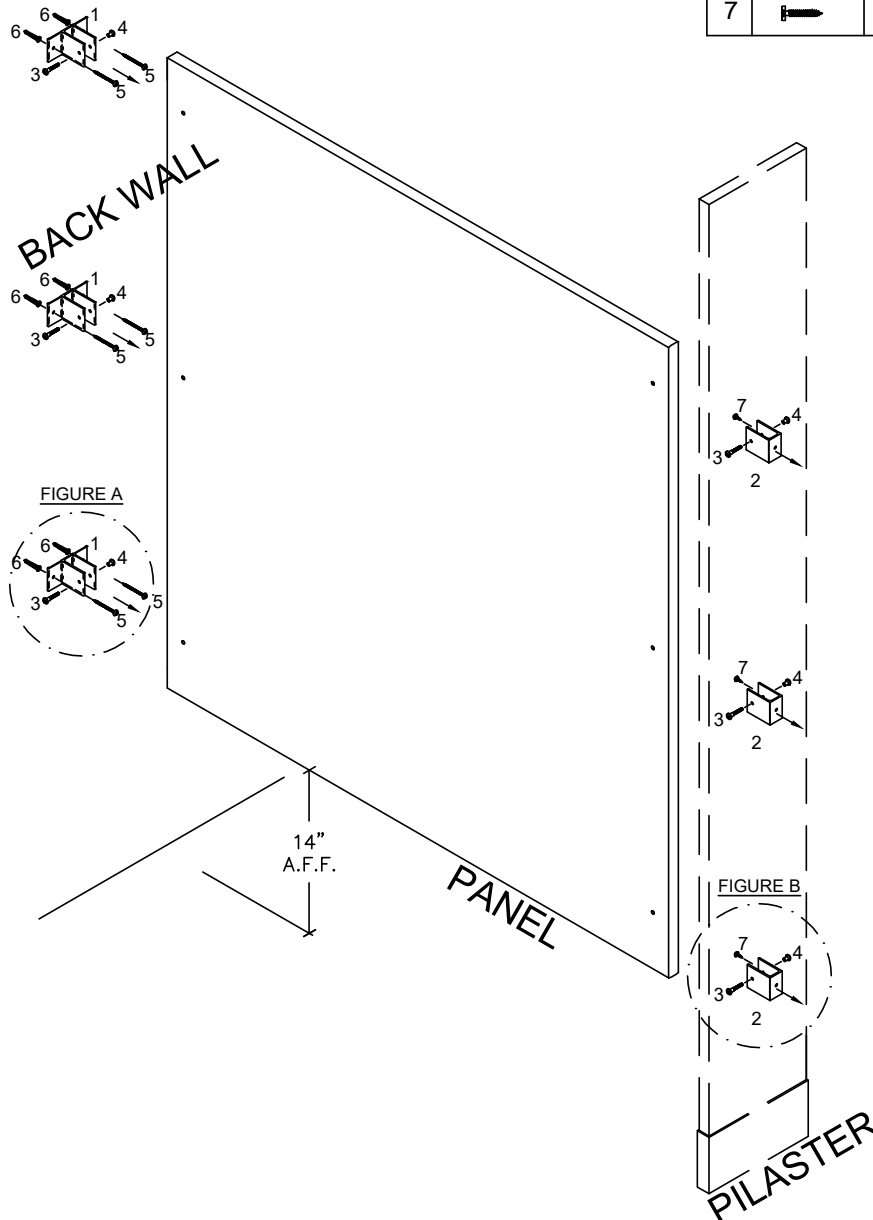

FIGURE A
Panel to wall

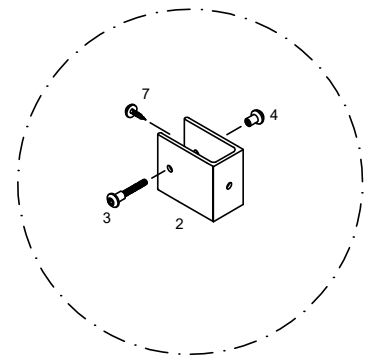









FIGURE B
Panel to pilaster

**FLOOR ANCHORED/OVERHEAD BRACED
PANEL TO PILASTER/WALL
ONE EAR ASSEMBLY
POLYMER**

Note: The tops of all pilasters must be level with one another prior to securing the pilaster to the panel.

- A. Level the panel and adjust the gaps at either end.
- B. Secure the panel to the wall using through bolts.
- C. Plumb the pilaster front to back
- D. Secure the pilaster to the panel using through bolts
- E. Remove panel support device.

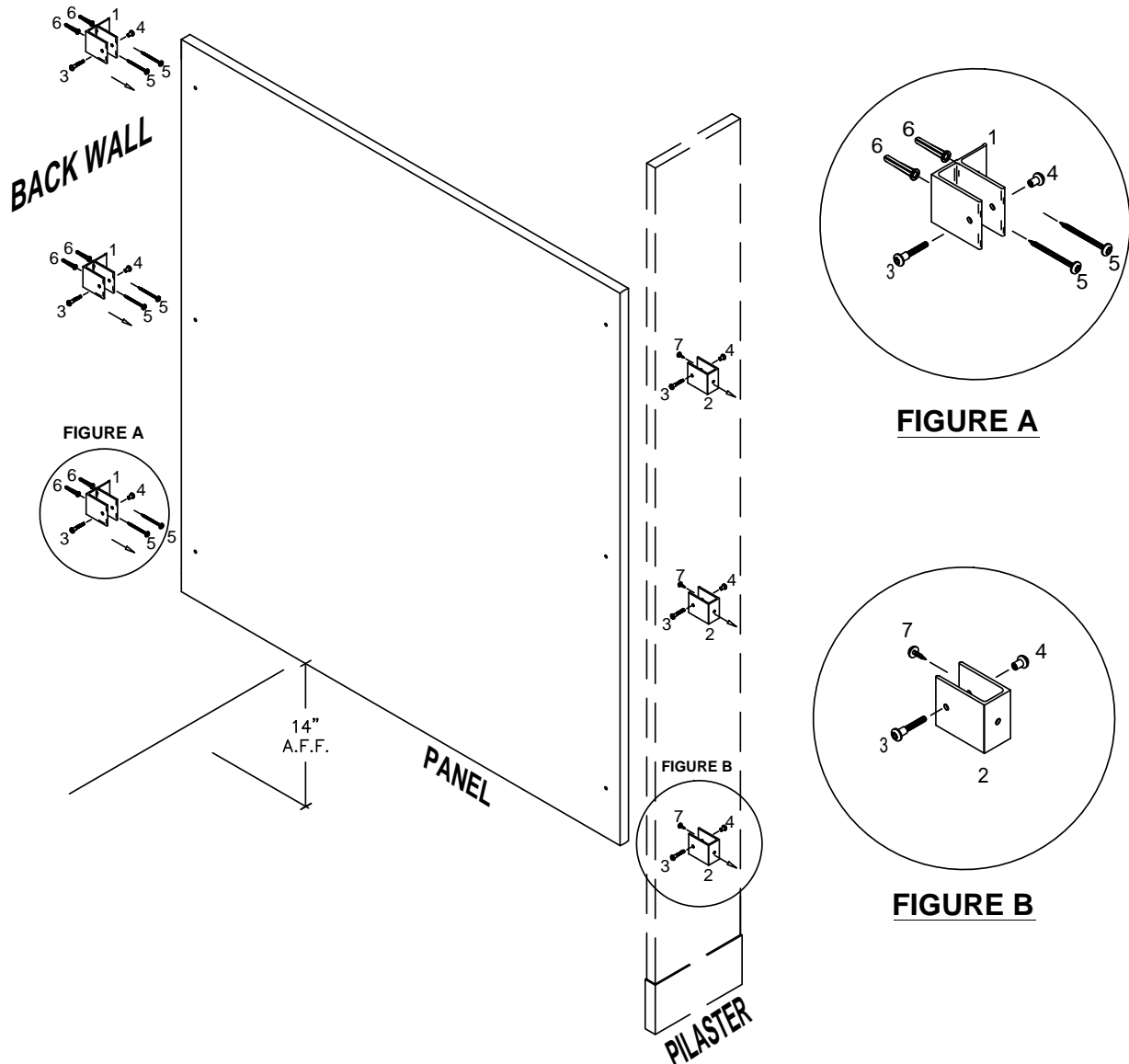

Aluminum Panel Hardware Kit (P/N 8445020) Includes			
PART ID.		DESCRIPTION	QTY
1		One Ear Alum. Bracket	(3)
2		Alum. "U" Bracket	(3)
3		Vandal Resistant 1" Step Bolt	(6)
4		Vandal Resistant 5/8" Barrel Nut	(6)
5		Vandal Resistant 2-1/2" Screw	(6)
6		Plastic Shield	(6)
7		Vandal Resistant 5/8" Screw	(3)



**FLOOR ANCHORED/OVERHEAD BRACED
PILASTER/WALL
ASSEMBLY
POLYMER**

Note: The tops of all pilasters must be level with one another prior to securing the pilaster to the wall.





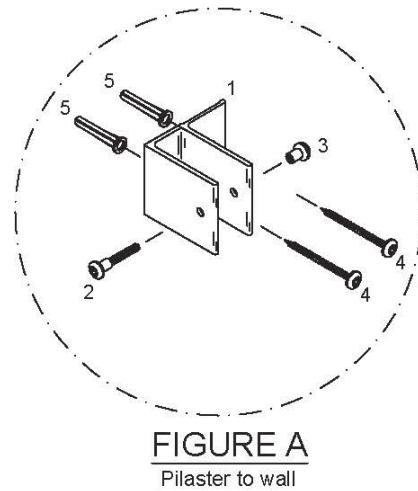
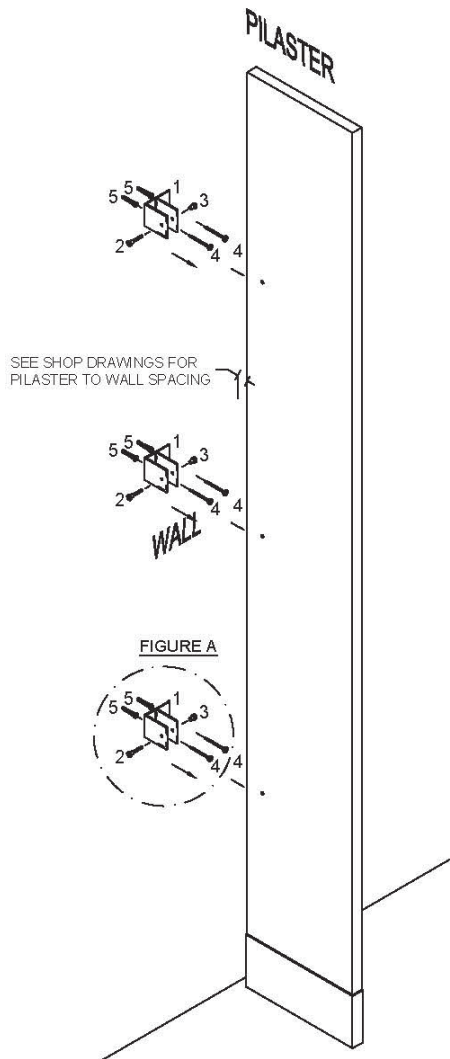



- A. Plumb the pilaster.
- B. Secure the pilaster to the wall using through bolts.

Pilaster/Wall Hardware Kit (P/N 8445210) Includes: ALUMINUM			
PART ID.		DESCRIPTION	QTY
1		One Ear Wall Bracket	(3)
2		Vandal Resistant Step Bolts 1" Long	(3)
3		Vandal Resistant S/S Barrel Nut	(2)
4		Vandal Resistant 2 1/2" S.M.S	(6)
5		Plastic Shelds	(6)
6		Vandal Resistant 3/4" S.M.S	(6)



**FLOOR ANCHORED/
OVERHEAD BRACED
PILASTER/PANEL ALCOVE
ASSEMBLY
POLYMER**

Optional #8447020 2-ear alcove kit.

Panel Hardware Kit (P/N 8447010) Includes: ALUMINUM			
PART ID.		DESCRIPTION	QTY
1		One Ear Alum. Bracket	(6)
2		Vandal Resistant 1" Step Bolts	(12)
3		Vandal Resistant 5/8" Barrel Nut	(12)
4		Vandal Resistant 2 1/2" SMS	(14)
5		Plastic Shields	(14)
6		Vandal Resistant 5/8" SMS	(3)
7		Alcove Clip S/S	(6)
8		Headrail Bracket	(1)

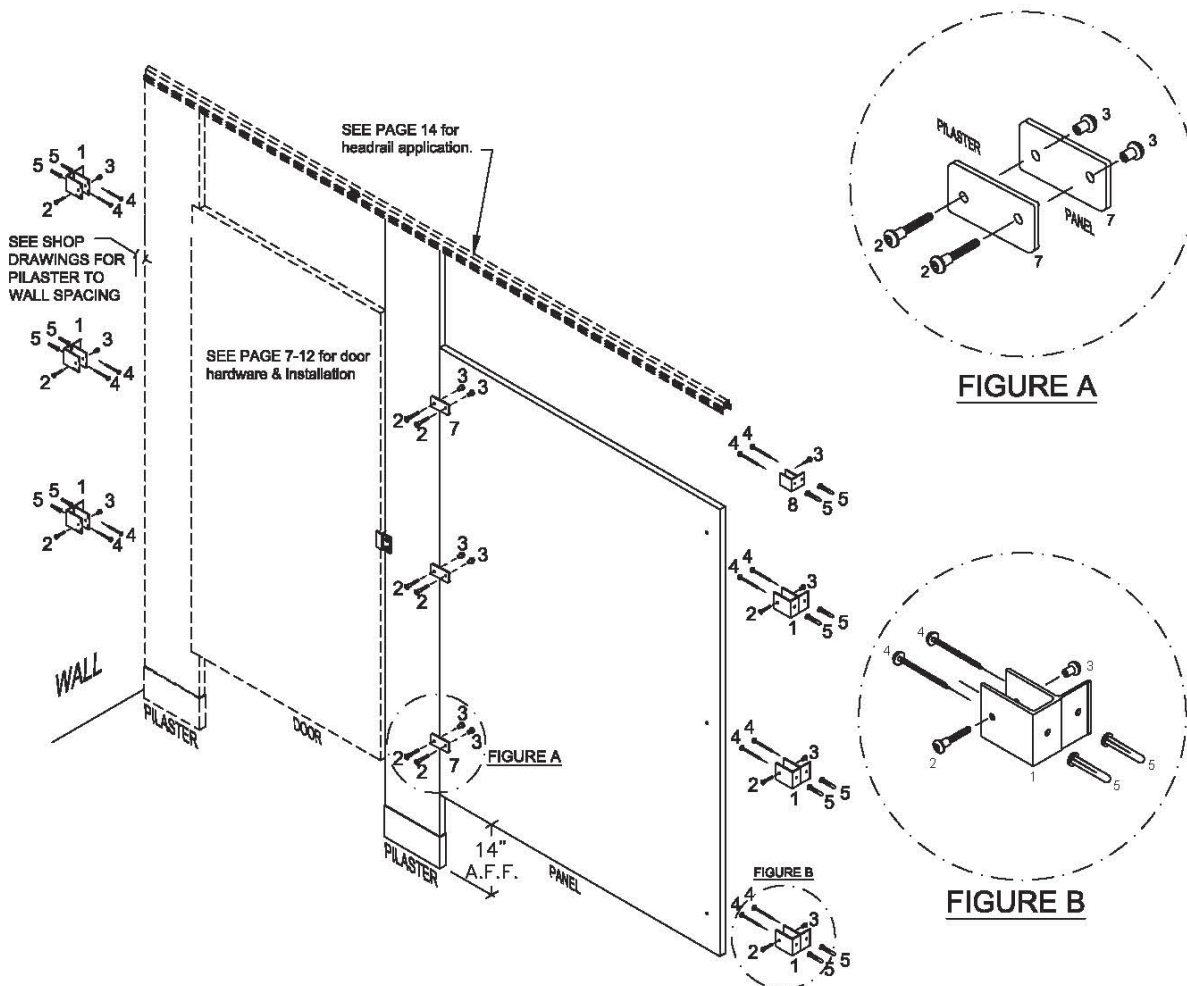

NOTE:
There will be no gap between the in-line panel and pilaster.

DOOR HARDWARE
ASSEMBLY-VAULT HINGE
POLYMER

Install slide latch on door oppsite the hinge side of door. All slide latches should be mounted at midpoint of the door , 27 1/2" inches up from the bottom of the door.

INSWING DOOR

Mount the slide latch on to the door with two (2) 1 inch step bolts and two (2) 5/8 inch barrel nuts. Install keeper and bumper on pilaster. Be sure that the keeper and bumper is set so that the slide bar of the slide latch engages the top notch of the keeper. Install keeper/bumper with one (1) 1 inch step bolt and one (1) 5/8 inch barrel nut.

ADJUSTING DOOR RESTING POSITION

Loosen 10 (Nut adjusting Bottom Hinge) and turn 8 (Cam Adjusting Bottom Hinge) until desired resting position is achieved. Tighten 10.

Inswing Door Hardware Kit (P/N 8571007) Includes: Brushed Finish		
PART ID.	DESCRIPTION	QTY
1	Vault Hinge Top Pilaster Side	(1)
2	Vault Hinge Top Door Side	(1)
3	Vault Hinge Bottom Door Side	(1)
4	Vault Hinge Bottom Pilaster Side	(1)
5	Side Latch Brushed Finish	(1)
6	Inswing Keeper Brushed	(1)
7	Bumper And Coathook	(1)
8	Cam Adjusting Bottom Hinge	(1)
9	Bushing Nylon Top Hinge	(1)
10	Nut Adjusting Bottom Hinge	(1)
11	Hinge Washer Internal	(1)
12	Vandal Resistant Barrel Nut 5/8"	(1)
13	Vandal Resistant 1"	(1)
14	Vandal Resistant 5/8"	(2)

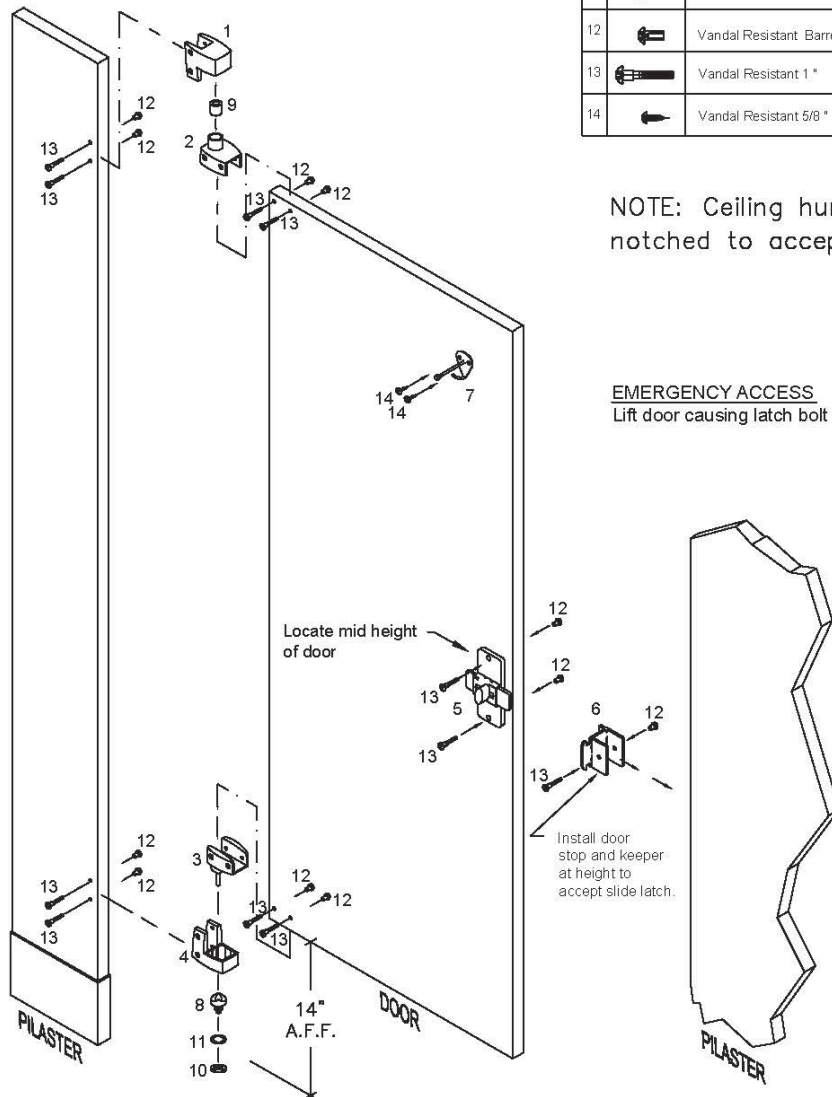

NOTE: Ceiling hung doors will be notched to accept bottom hinge.

EMERGENCY ACCESS

Lift door causing latch bolt to clear keeper and open.

DOOR HARDWARE
ASSEMBLY-VAULT HINGE - OUTSWING
POLYMER

Install slide latch on door opposite the hinge side of door. All slide latches should be mounted at midpoint of the door, 27 1/2" inches up from the bottom of the door.

OUTSWING DOOR

Mount the slide latch to the inside face of door. Use two (2) 1 inch step bolts and two (2) 5/8 inch barrel nuts.

















Be sure that the keeper is set so that the slide latch bar is only 1/4 inch (.250) below the top edge of the keeper and does not engage behind pilaster (bumper only). Install keeper with one (1) 1 inch step bolt and one (1) 5/8 inch barrel nut.

ADJUSTING DOOR RESTING POSITION

Loosen 10 (Nut adjusting Bottom Hinge) and turn 8 (Cam Adjusting Bottom Hinge) until desired resting position is achieved. Tighten 10.

EMERGENCY ACCESS

Lift door causing latch bolt to clear keeper and open.

Outswing Door Hardware Kit (P/N 8571008) Includes: Brushed Finish		
PART ID.	DESCRIPTION	QTY
1	 Vault Hinge Top Pilaster Side	(1)
2	 Vault Hinge Top Door Side	(1)
3	 Vault Hinge Bottom Door Side	(1)
4	 Vault Hinge Bottom Pilaster Side	(1)
5	 Side Latch Brushed Finish	(1)
6	 Outswing Slide Latch Keeper	(1)
7	 Pull Handle	(1)
8	 Cam Adjusting Bottom Hinge	(1)
9	 Bushing Nylon Top Hinge	(1)
10	 Nut Adjusting Bottom Hinge	(1)
11	 Hinge Washer Internal	(1)
12	 Bumper And Coathook	(1)
13	 Bumper	(1)
14	 Vandal Resistant Step Bolts 1"	(10)
15	 Vandal Resistant Barrel Nut 5/8"	(10)
16	 Vandal Resistant 5/8" SMS"	(4)

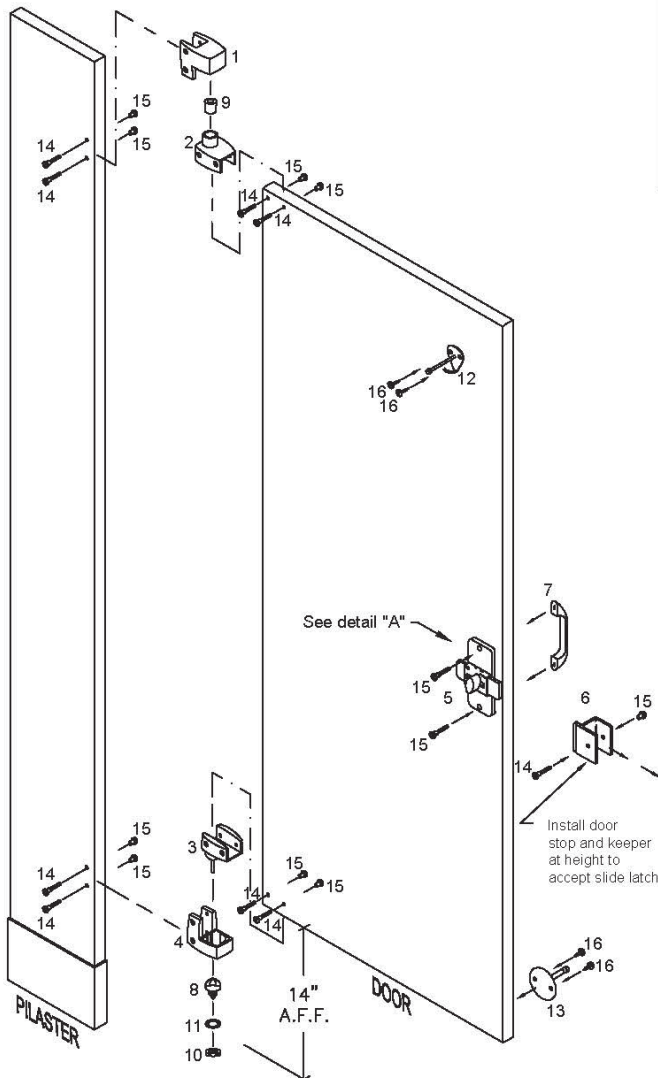

NOTE: Ceiling hung doors will be notched to accept bottom hinge

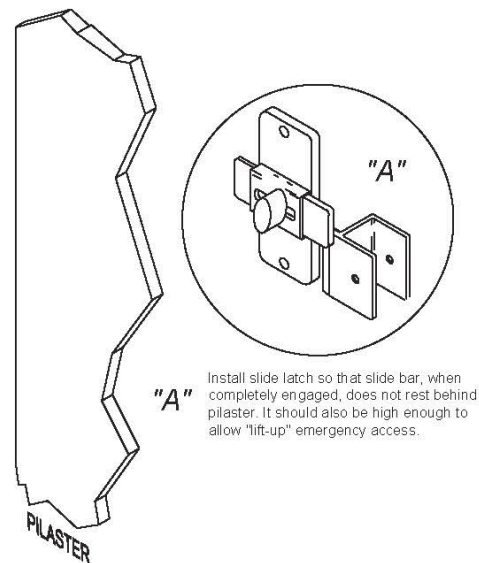

DOOR HARDWARE INSWING 8" WRAP HINGE - POLYMER

HINGES

Hinge kit will contain aluminum housings and toothed plastic inserts. Plastic cam (#3) will be inserted into one of the aluminum housings (#1). This will be the bottom half of the top hinge (pilaster side). Insert female plastic insert (#4) into an aluminum housing. This will be the top half of the upper hinge (door side). (To set closing position of door, mate toothed cam into aluminum housing until desired setting is achieved.)











Insert non-cammed hinge pin (#2) into an aluminum housing. This will be the top half of the lower hinge (pilaster side). The remaining female plastic insert should be placed into aluminum housing and coupled with other half of hinge. Proceed to mark door and secure hinges to edge of pilaster and door with flathead screws (#11) with the exception of the bottom door hinge. This will be secured after door is hung on pilaster.

Through-bolt all holes with provided step-bolts and barrel nuts.

LATCH & BUMPER

Install slide latch at midpoint of the door, 27 1/2" inches up from the bottom of the door. Beveled side should face up to allow for emergency access when door is lifted.

Mount the slide latch on to the door with two (2) step bolts and two (2) barrel nuts. Install keeper and bumper on pilaster. Be sure that the keeper and bumper is set so that the slide bar of the slide latch engages the notch of the keeper. Install keeper/bumper with three (3) step bolts and three (3) barrel nuts.

Door Hardware Kit (P/N 8441007) Includes:			
PART ID.		DESCRIPTION	QTY
1		4" Aluminum Housings	(4)
2		Top Hinge Plastic Male Insert	(1)
3		Bottom Hinge Cammed Insert	(1)
4		Female Plastic Insert	(2)
5		Stop and Keeper	(1)
6		Slide Latch	(1)
7		Tamper Resistant Step Bolts 1"	(21)
8		Tamper Resistant Barrel Nut 1/2"	(21)
9		Bumper And Coathook	(1)
10		Tamper Resistant Screw 5/8"	(2)
11		Flathead Screw 5/8"	(4)

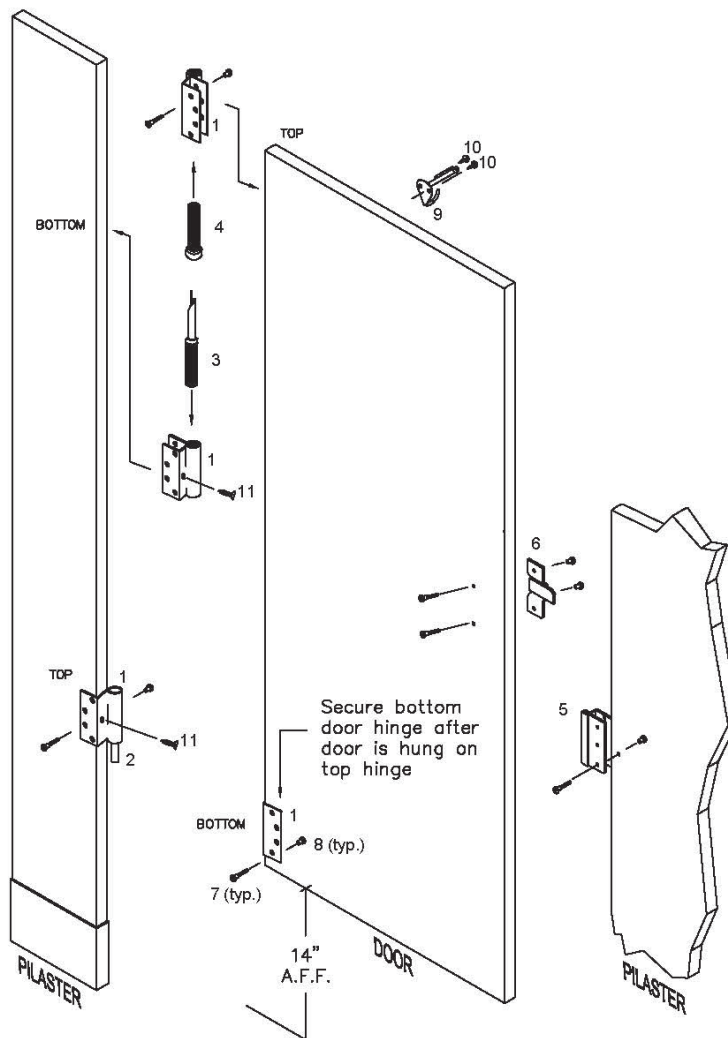

DOOR HARDWARE OUTSWING 8" WRAP HINGE - POLYMER

HINGES

Hinge kit will contain aluminum housings and toothed plastic inserts. Plastic cam (#3) will be inserted into one of the aluminum housings (#1). This will be the bottom half of the top hinge (pilaster side). Insert female plastic insert (#4) into an aluminum housing. This will be the top half of the upper hinge (door side). (To set closing position of door, mate toothed cam into aluminum housing until desired setting is achieved.)















Insert non-cammed hinge pin (#2) into an aluminum housing. This will be the top half of the lower hinge (pilaster side). The remaining female plastic insert should be placed into aluminum housing and coupled with other half of hinge. Proceed to mark door and secure hinges to edge of pilaster and door with flathead screws (#11) with the exception of the bottom door hinge. This will be secured after door is hung on pilaster.

Through-bolt all holes with provided step-bolts and barrel nuts.

LATCH & BUMPER

Install slide latch at midpoint of the door, 27 1/2" inches up from the bottom of the door. Beveled side should face up to allow for emergency access when door is lifted.

Mount the slide latch on to the door with two (2) step bolts and two (2) barrel nuts. Install keeper and bumper on pilaster. Be sure that the keeper and bumper is set so that the slide bar of the slide latch engages the notch of the keeper. Install keeper/bumper with three (3) step bolts and three (3) barrel nuts.

Door Hardware Kit (P/N 8441007) Includes:			
PART ID.		DESCRIPTION	QTY
1		4" Aluminum Housings	(4)
2		Top Hinge Plastic Male Insert	(1)
3		Bottom Hinge Cammed Insert	(1)
4		Female Plastic Inserts	(2)
5		Stop and Keeper	(1)
6		Slide Latch	(1)
7		Vandal Resistant S/S Step Bolts	(27)
8		Vandal Resistant S/S Barrel Nut	(27)
9		Bumper And Coathook	(1)
10		Vandal Resistant S/S Screw	(2)
11		Flathead S/S Screw 5/8"	(4)
Optional Third Hinge (P/N 844 XXXX) Includes:			
		Non-Cammed Insert	(1)
		4" Aluminum Housings	(2)
		Female Plastic Insert	(1)

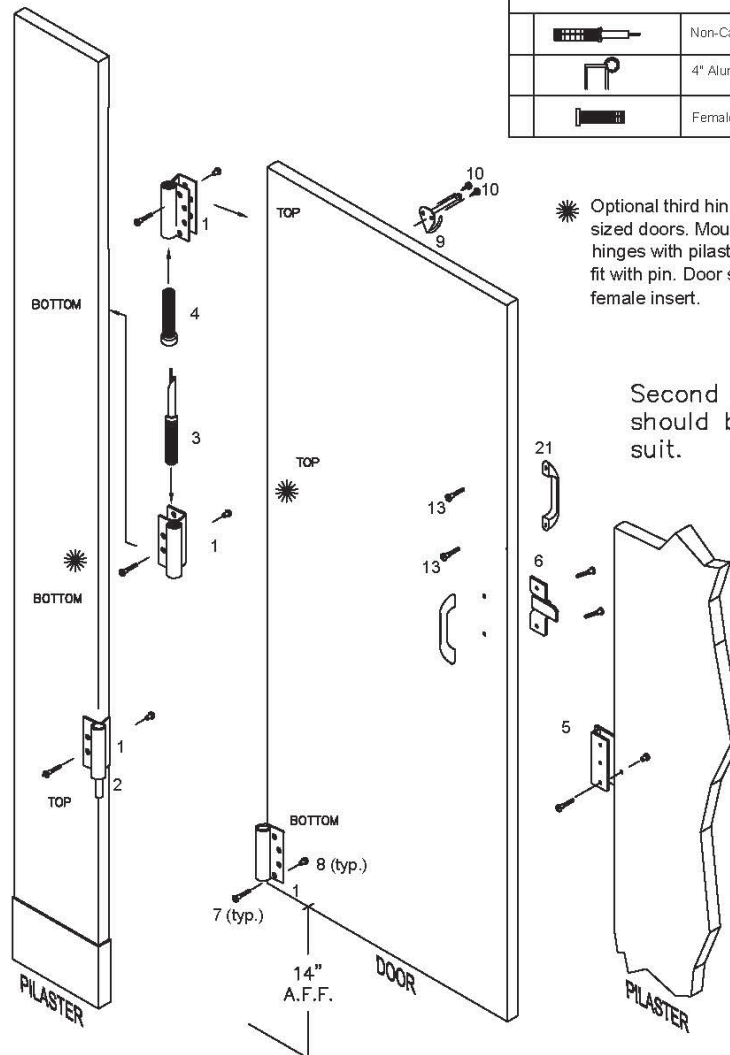







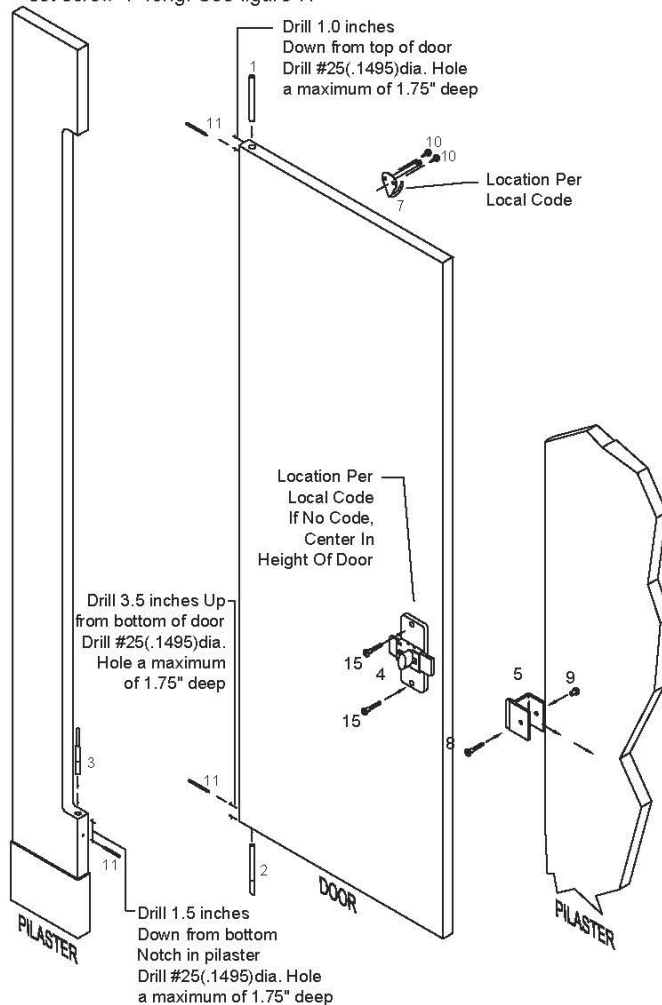



* Optional third hinge may be used for larger sized doors. Mount between two standard hinges with pilaster side hinge as lower half fit with pin. Door side will be upper and fit female insert.

DOOR HARDWARE
ASSEMBLY-INTEGRAL HINGE
POLYMER

- A. Insert bottom integral hinge cam side into door with high/low points parallel with door. See figure 1. Pin unit to door by drilling #25(.1495)dia.hole a minimum of 1.75" deep through edge of door and hinge as noted on dwg. Lock edge of door and hinge lock unit into place with #10-24 cap point set screw 1" long. See figure 2.
- B. Insert bottom integral hinge pin side into pilaster. See figure 3. Set door over bottom hinge. Hold door at an in tilt. Insert top integral hinge into hole at top of pilaster. See figure 4. Align door and let top pin fall into hole at top of door. See figure 5. Door is hung.
- C. Set door position. Closed for outswing door, open for inswing door. When door position is set drill #25(.1495) dia. hole a minimum of 1.75" deep through the pilaster edge and hinge at bottom. Lock hinge into place with #10-24 cap point set screw 1" long. See figure 6.
- D. Drill #25(.1495) dia. hole a minimum of 1.75" deep through both top hinge and door. Lock top pin into place using #10-24 cap point set screw 1" long. See figure 7.



Inswing Door Hardware Kit (P/N 8981000) Includes:		
PART ID.	DESCRIPTION	QTY
1	 Top Integral Hinge Pin Nylon	(1)
2	 Bottom Integral Hinge Cam Side Nylon	(1)
3	 Bottom Integral Hinge Pin Nylon With 3/16" pin	(1)
4	 Side Latch Brushed Finish	(1)
5	 Door Stop and Keeper Brushed Finish	(1)
7	 Bumper And Coathook	(1)
8	 Vandal Resistant Step Bolts 1"	(6)
9	 Vandal Resistant Barrel Nut 5/8"	(6)
10	 Vandal Resistant 5/8" SMS	(2)
11	 P/H screw #10-24 x 1" Cap Point Set Screw	(4)



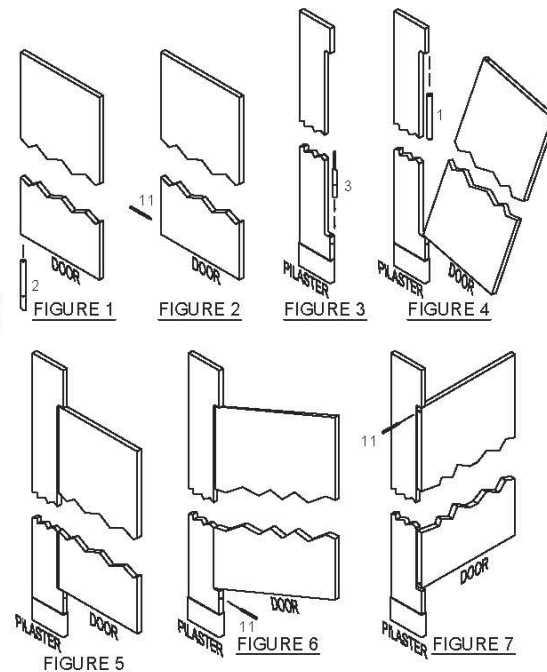







Outswing Door Hardware Kit (P/N 8981010) Includes:		
PART ID.	DESCRIPTION	QTY
13	 Pull Handle	(1)
14	 Bumper	(1)
15	 Vandal Resistant Step Bolts 1-1/4"	(4)
16	 Vandal Resistant 5/8" SMS	(2)



DOOR HARDWARE
ASSEMBLY-PIANO HINGE
POLYMER

NOTE

- OUTSWING DOOR HINGE FASTENED TO OUTSIDE FACE
- INSWING DOOR HINGE FASTENED TO INSIDE FACE

PART ID.	DESCRIPTION	QTY
1	 Side Latch Brushed Finish	(1)
2	 Slide Latch Keeper	(1)
3	 Pull Handle	(1)
4	 Vandal Resistant S/S Step Bolts 1"	(8)
5	 Bumper And Coathook	(1)
6	 Vandal Resistant S/S Step Bolts #10-24 x 1 1/4 "	(3)
7	 Vandal Resistant S/S 5/8 "	(4)
8	 Vandal Resistant S/S Barrel Nut 5/8"	(1)
9	 Bumper	(1)
10	 Spring-Loaded Piano Hinge	(1)

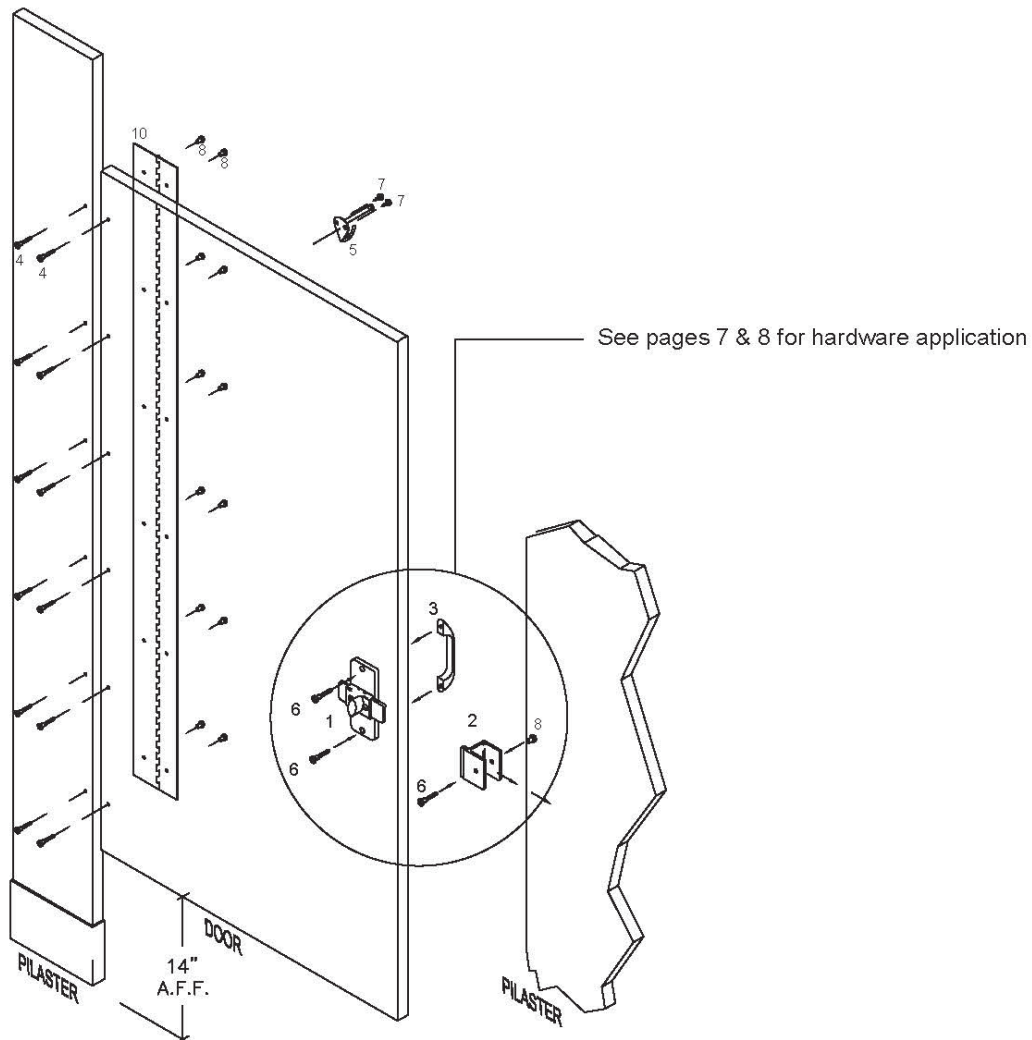

**HEADRAIL
ASSEMBLY
POLYMER**

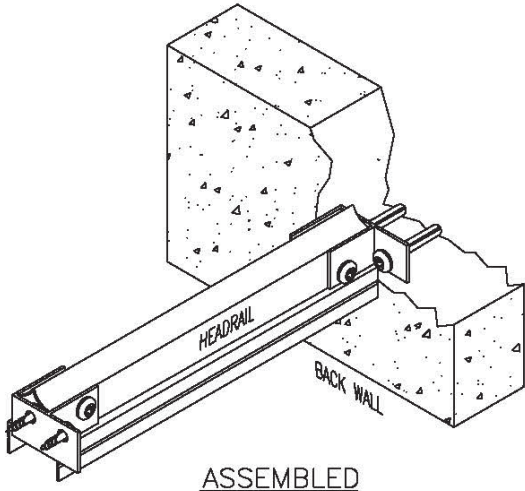

Headrail Hardware Kit (P/N 8448100) Includes:

PART ID.	DESCRIPTION	QTY
1	Headrail Satin "F" Zamac Bracket	(2)
2	Headrail Cap Satin Zamac	(1)
3	Vandal Resistant 2 1/2" S.M.S	(2)
4	Plastic Shield 14/16 x 1-1/2"	(2)
5	Vandal Resistant 5/8" S.M.S	(4)



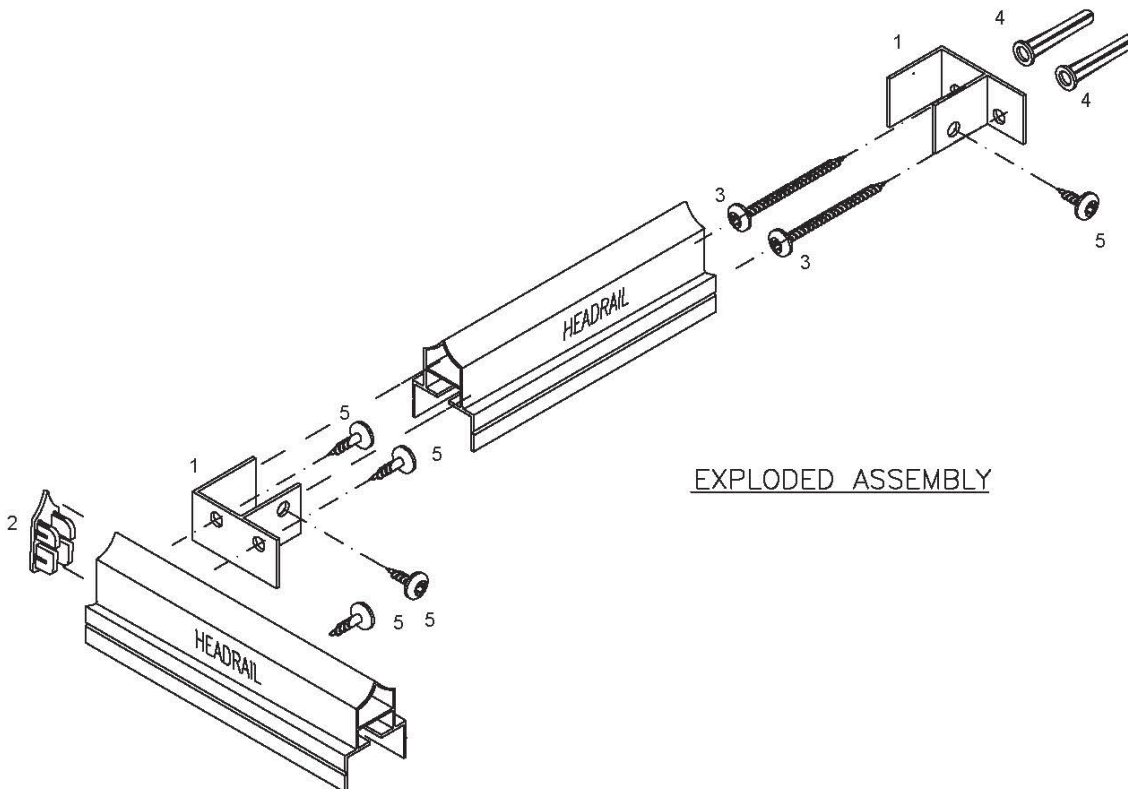

5	Theft Resistant S/S #14 x 5/8" S.M.S	(x)
---	--------------------------------------	-----

Additional Vandal Resistant 5/8" S.M.S will be included based upon headrail length



**URINAL SCREEN FULL HEIGHT
ASSEMBLY
POLYMER**

- A. Before proceeding, confirm that backing of wall is adequate to support and secure mounting of urinal screens.
- B. Insert anchoring devices in walls and secure wall brackets.
- C. Place urinal screen on a support, 14" above the floor.
- D. Set it into wall bracket and fasten urinal screen with through bolts at this time.

Urinal Screen Hardware Kit (P/N 8449000) Includes: ALUMINUM FULL HEIGHT		
PART ID.	DESCRIPTION	QTY
1	 38" Long Two Ear Wall U/S Bracket	(1)
2	 Vandal Resistant 2 1/2" S.M.S	(8)
3	 Plastic Shields	(8)
4	 Vandal Resistant S/S Step Bolts 1" Long	(4)
5	 Vandal Resistant S/S Barrel Nut	(4)

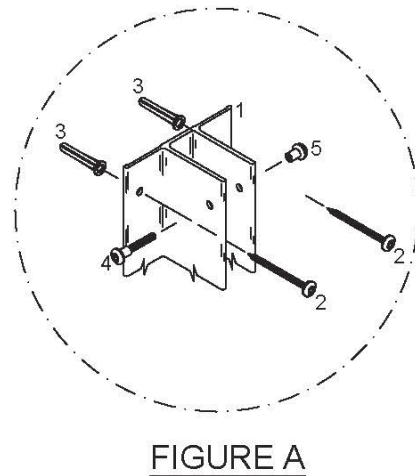
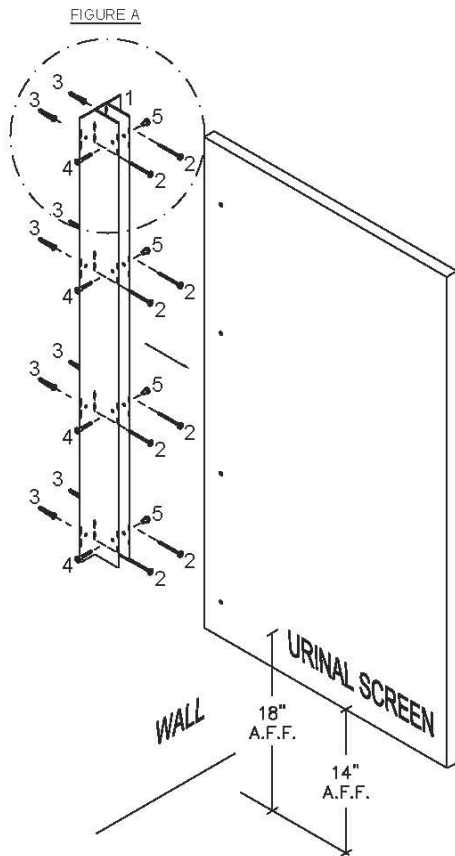

STEP 1
LAYOUT
CEILING ANCHORED

STRUCTURAL SUPPORT BY OTHERS

- A. Review the layout drawings and package lists that have accompanied this job.
- B. Before proceeding, confirm that backing of wall and ceiling is adequate to support secure mounting of toilet compartment units.
- C. Confirm correct location and condition of threaded ceiling rods. These should project 2" to 2-1/2" below finished ceiling.
- D. Establish and mark pilaster and panel center lines in relation to ceiling rod locations on drawings.
- E. Mark wall bracket holes using brackets as templates.

FIGURE 1

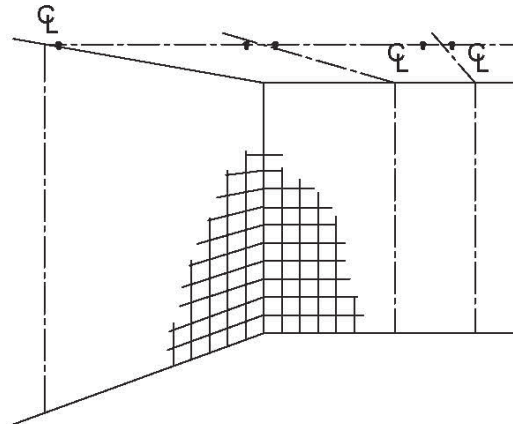

STEP 2
WALL BRACKETS AND CEILING ANCHORS

- A. Drill holes for wall brackets of appropriate size for particular fastening devices supplied. Typically, 1/4" bits for walls and compartment thru-bolts, and 3/8" bit for floors. As site conditions and hardware combinations vary, an assortment of bit sizes are recommended.
- B. Insert anchoring devices in walls and secure wall brackets.
- C. Pilaster at wall should be prepared for wall and ceiling fastening as required by compartment layout.

FIGURE 2

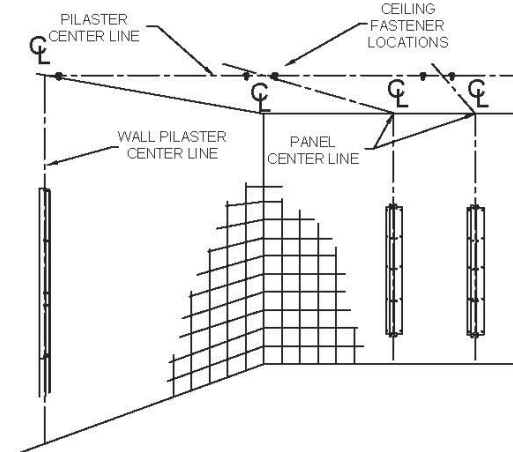

STEP 3
POSITION PANEL

- A. Place panel on a support, 14" above the floor.
 - B. Set it into wall brackets, but do not fasten panel at this time.
- NOTE: Metal heat-sink strip will be on bottom of panel.

FIGURE 3

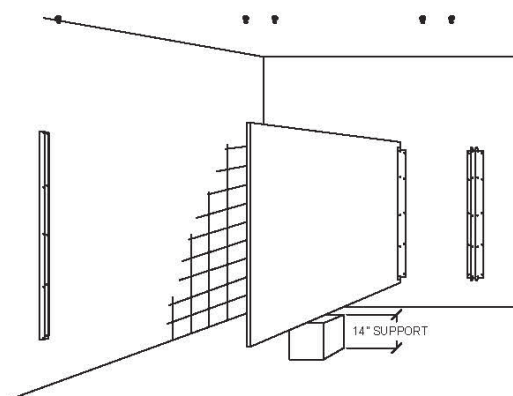

STEP 4 PILASTER PREPARATION

- A. Align brackets in position on rear of pilasters. Refer to layout drawings.
- B. Fasten brackets to pilaster with sheet metal screws.
- C. Pilasters at wall do not require brackets, but should be prepared for wall and ceiling fastening as required by compartment layout.

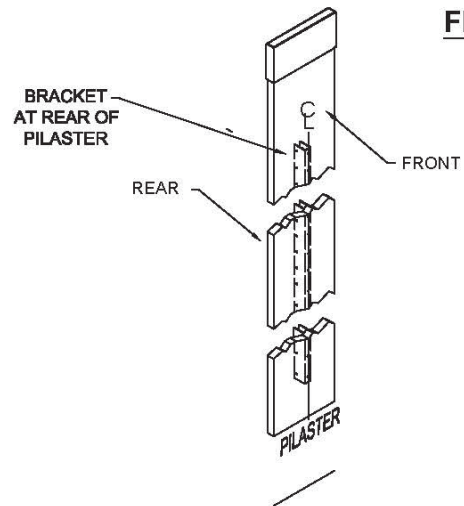

FIGURE 4

STEP 5 INSTALL PILASTERS

- A. Slide shoe carefully over mounting end of pilaster and leave approximately 5" above end.
- B. Thread support nuts and mounting washers over stud to support pilaster mounting bar.
- C. Position pilaster and mounting bar on threaded anchor and attach lightly with shoe clip if plastic shoe using square flat washer, lockwasher and locking nut. If stainless shoe no clip required.

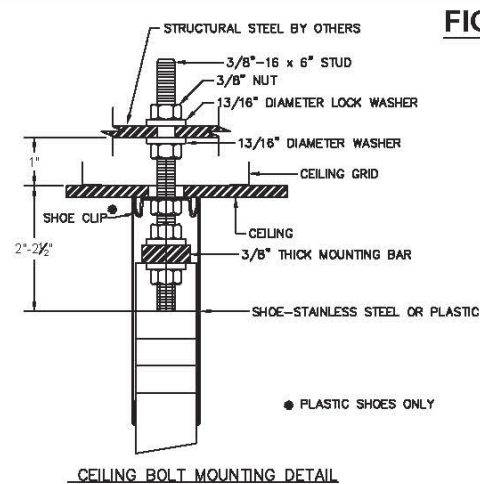

FIGURE 5

STEP 6 SECURING PILASTER/PANEL

- A. Level each pilaster by adjusting both support nuts to desired position.
- B. Plumb each pilaster and fasten the pilaster to panel using through bolts.
- C. Establish door openings by setting pilaster mounting bar to desired position on anchor.
- D. Tighten locking nuts on top of pilaster mounting bar.
- E. Slide shoe up to ceiling level. If plastic shoe, engage shoe clips. If stainless steel shoe, secure with screw.
- F. Fasten panel to wall brackets using through bolts.
- G. Once doors are installed, attach cross-bracing with 1 3/4" screws.

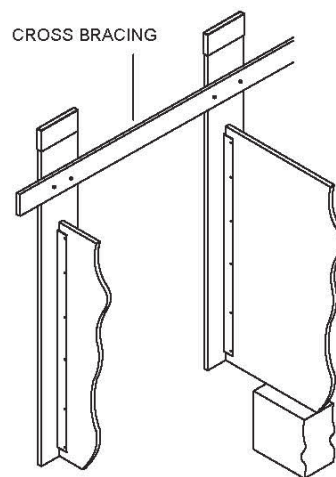









FIGURE 6

**CEILING HUNG
PANEL TO PILASTER/WALL
TWO EAR ASSEMBLY
POLYMER**

Pilasters must be both plumb and level.

- A. Plumb pilaster and fasten pilaster to panel using through bolts.
- B. Plumb panel and fasten panel to 2-ear bracket at wall with through bolts and barrel nuts.

Panel Hardware Kit (P/N 8466020) Includes: ALUMINUM FULL HEIGHT		
PART ID.	DESCRIPTION	QTY
1	 Two Ear Bracket	(1)
2	 "U" Bracket	(1)
3	 Vandal Resistant S/S Step Bolts 1" Long	(12)
4	 Vandal Resistant S/S Barrel Nut	(12)
5	 Vandal Resistant S/S 2 1/2" S.M.S	(12)
6	 Plastic Shields	(12)
7	 Vandal Resistant S/S 5/8" S.M.S	(12)

OPTIONAL:
(P/N 8986020) PLASTIC FULL HEIGHT BRACKET.

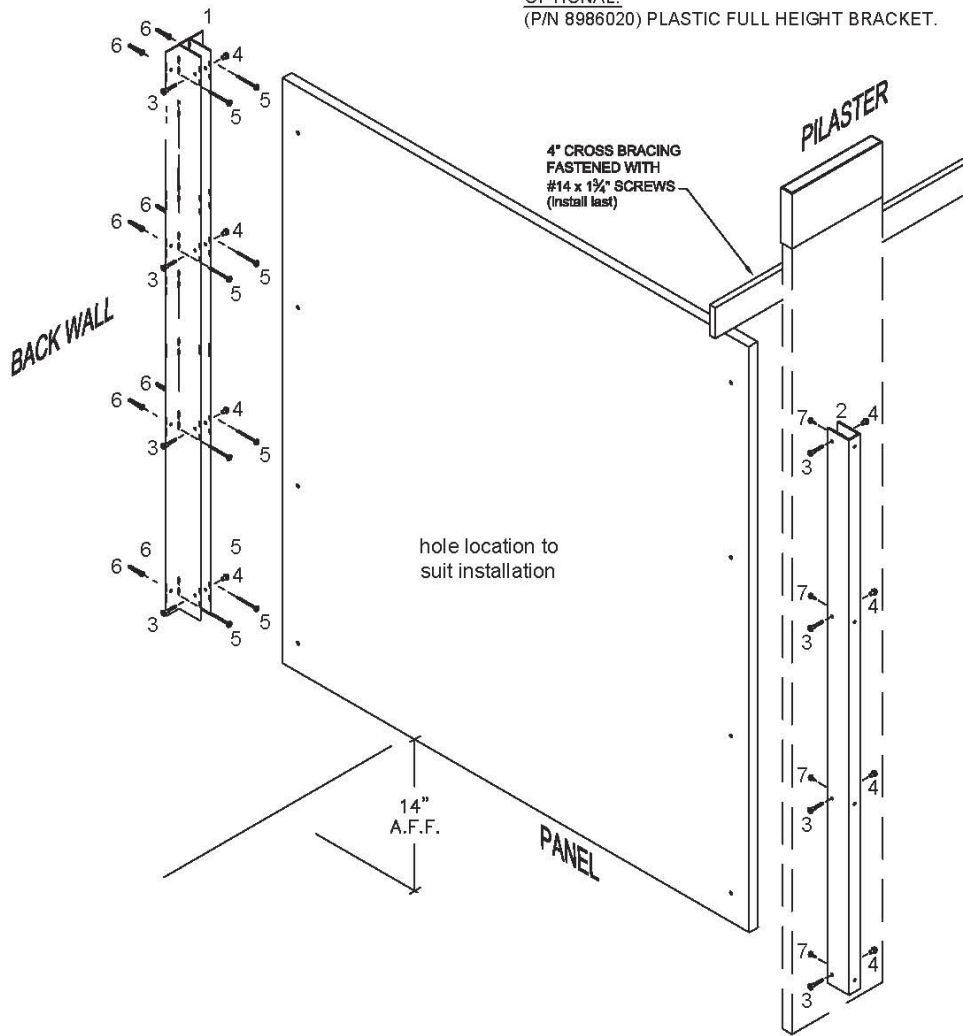

**CEILING HUNG
PILASTER/WALL
ASSEMBLY
POLYMER**

Pilasters must be both plumb and level.

- A. Plumb pilaster and fasten pilaster to wall using through bolts or sheet metal screws.
- B. Establish bottom door openings by adjusting pilaster mounting bar nuts to desired position and tightening screws.



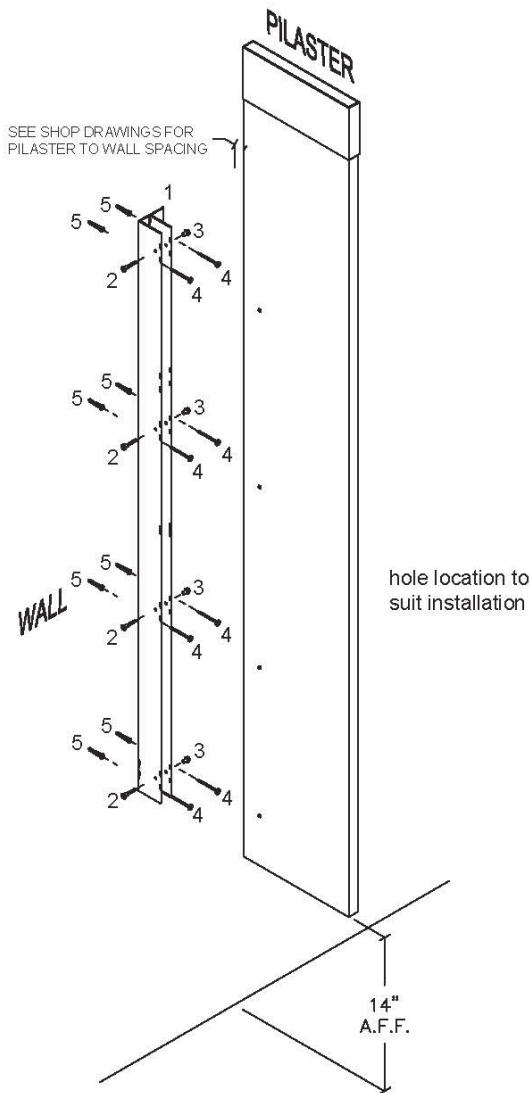



Pilaster/Wall Hardware Kit (P/N 8466210) Includes: ALUMINUM FULL HEIGHT			
PART ID.		DESCRIPTION	QTY
1		One Ear Wall Bracket	(1)
2		Vandal Resistant S/S Step Bolts 1" Long	(6)
3		Vandal Resistant S/S Barrel Nut	(6)
4		Vandal Resistant S/S 2 1/2" S.M.S	(12)
5		Plastic Shields	(12)



**CEILING HUNG
PILASTER/PANEL ALCOVE
ASSEMBLY
POLYMER**







Pilasters must be both plumb and level.

- A. Plumb pilaster and fasten pilaster to panel using through bolts.
- B. Plumb panel and fasten panel to 1-ear bracket at wall with through bolts and barrel nuts or sms.

Panel Hardware Kit (P/N 8466010) Includes: ALUMINUM FULL HEIGHT		
PART ID.	DESCRIPTION	QTY
1	 One Ear Bracket	(1)
2	 "U" Bracket	(1)
3	 Vandal Resistant S/S Step Bolts 1" Long	(12)
4	 Vandal Resistant S/S Barrel Nut	(12)
5	 Vandal Resistant S/S 2 1/2" S.M.S	(12)
6	 Plastic Shields	(12)
7	 Vandal Resistant S/S 5/8" S.M.S	(12)

OPTIONAL:
(P/N 8986010) PLASTIC FULL HEIGHT BRACKET.

OR

Panel Hardware Kit (P/N 8466020) Includes: ALUMINUM FULL HEIGHT		
PART ID.	DESCRIPTION	QTY
1	 Two Ear Bracket	(1)
2	 "U" Bracket	(1)
3	 Vandal Resistant S/S Step Bolts 1" Long	(12)
4	 Vandal Resistant S/S Barrel Nut	(12)
5	 Vandal Resistant S/S 2 1/2" S.M.S	(12)
6	 Plastic Shields	(12)
7	 Vandal Resistant S/S 5/8" S.M.S	(12)

OPTIONAL:
(P/N 8986020) PLASTIC FULL HEIGHT BRACKET.

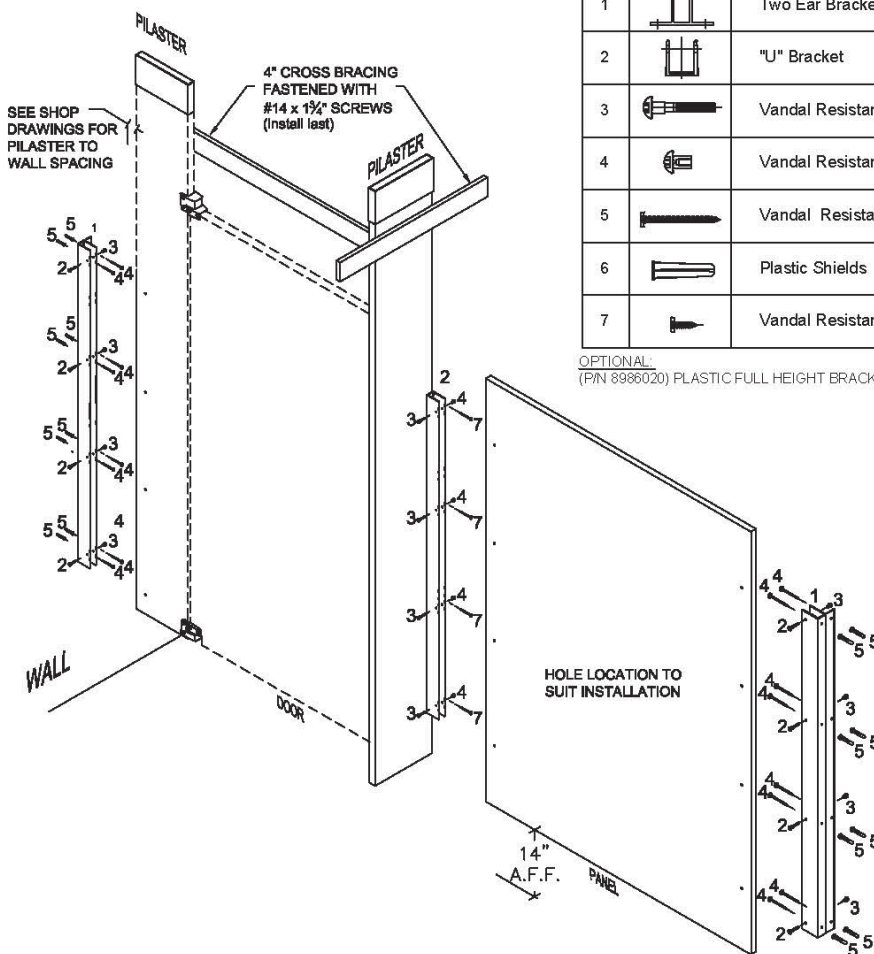

STEP 1 LAYOUT

FLOOR ANCHORED/CEILING ANCHORED

STRUCTURAL CEILING SUPPORT BY OTHERS
FLOOR MUST BE CONCRETE

- Review the layout drawings and package lists that have accompanied this job.
- Before proceeding, confirm that backing of wall and ceiling support is adequate to secure mounting of toilet compartment units.
- Establish and mark pilaster center line from back wall.
- Establish and mark panel center lines for wall brackets.
- Establish pilaster floor and ceiling fastener locations from side wall according to shop drawings. (Note fasteners are located 3/4" from edge of pilaster.)
- Confirm correct location and condition of threaded ceiling rods. These should project 2" to 2-1/2" below finished ceiling. Establish pilaster floor fastener location. Refer to layout dwgs.
- Mark wall bracket holes using brackets as templates.

FIGURE 1

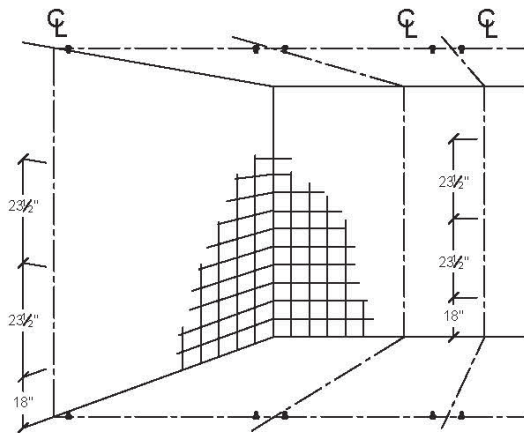

STEP 2 WALL BRACKETS AND FLOOR/CEILING FASTENERS

- Drill holes for wall brackets and floor anchors of appropriate size for particular fastening devices supplied. Typically, 1/4" bit for walls and compartment thru-bolts, and 3/8" bit for floors. As site conditions and hardware combinations vary, an assortment of bit sizes are recommended.
- Insert wedge anchor in concrete floor and secure wall brackets.
- Insert ceiling bolts and tighten.

FIGURE 2

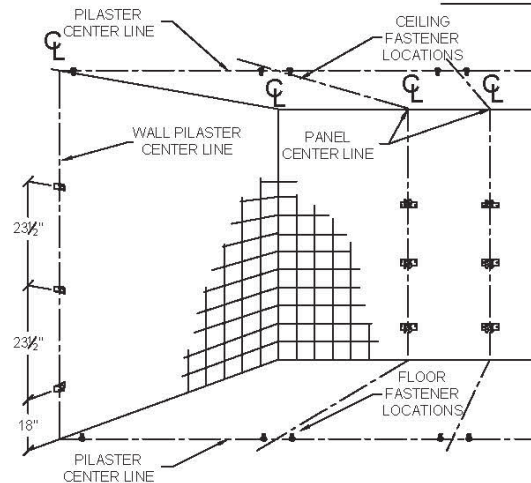

STEP 3 POSITION PANEL

- Place panel on a support, 14" above the floor.
 - Set it into wall brackets, but do not fasten panel at this time.
- NOTE: Metal heat-sink strip will be on bottom of panel.

FIGURE 3

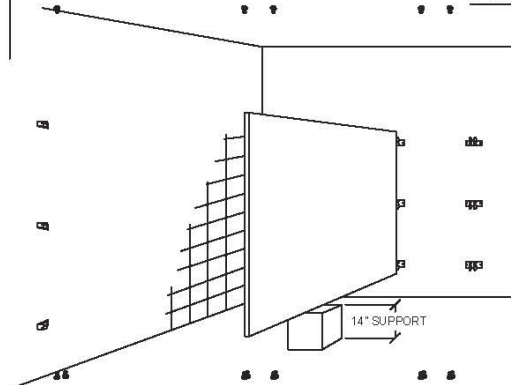

STEP 4 PILASTER PREPARATION

- A. Align brackets in position on rear of pilasters. Refer to layout drawings.
- B. Fasten brackets to pilaster with sheet metal screws.

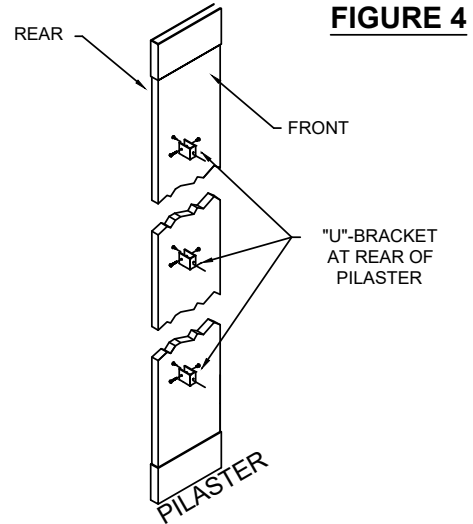

FIGURE 4

STEP 5 INSTALL PILASTERS

- A. Slide shoes carefully over ends of pilaster and leave approximately 5" above end or below mounting.
- B. Position pilaster and mounting bar on threaded anchor and attach lightly with shoe clip square flat washer, lockwasher and locking nut. If stainless steel shoes no clip needed.

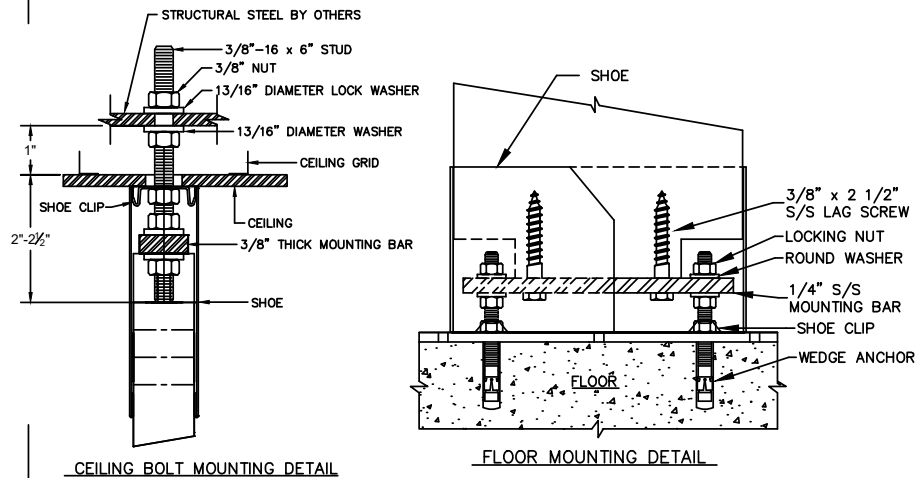

FIGURE 5

STEP 6 SECURING PILASTER/PANEL

- A. Level each pilaster by adjusting both support nuts to desired position.
- B. Plumb each pilaster and fasten the pilaster to panel using through bolts.
- C. Establish door openings by setting pilaster mounting bar to desired position on stud.
- D. Tighten locking nuts on top of pilaster mounting bar.
- E. Slide shoe up to ceiling level, and down to floor firmly engaging shoe clips. If stainless steel use screws.
- F. Fasten panel to wall brackets using through bolts.
- G. Remove panel support device.

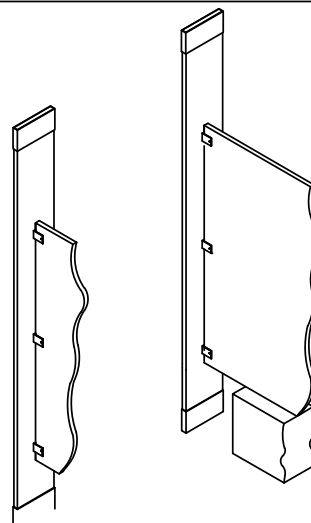









FIGURE 6

**FLOOR TO CEILING
PANEL TO PILASTER/WALL
TWO EAR ASSEMBLY
POLYMER**

Note: The tops of all pilasters must be level with one another prior to securing the pilaster to the panel.

- A. Level the panel and adjust the gaps at either end.
- B. Secure the panel to the wall using through bolts.
- C. Plumb the pilaster front to back
- D. Secure the pilaster to the panel using through bolts
- E. Remove panel support device.



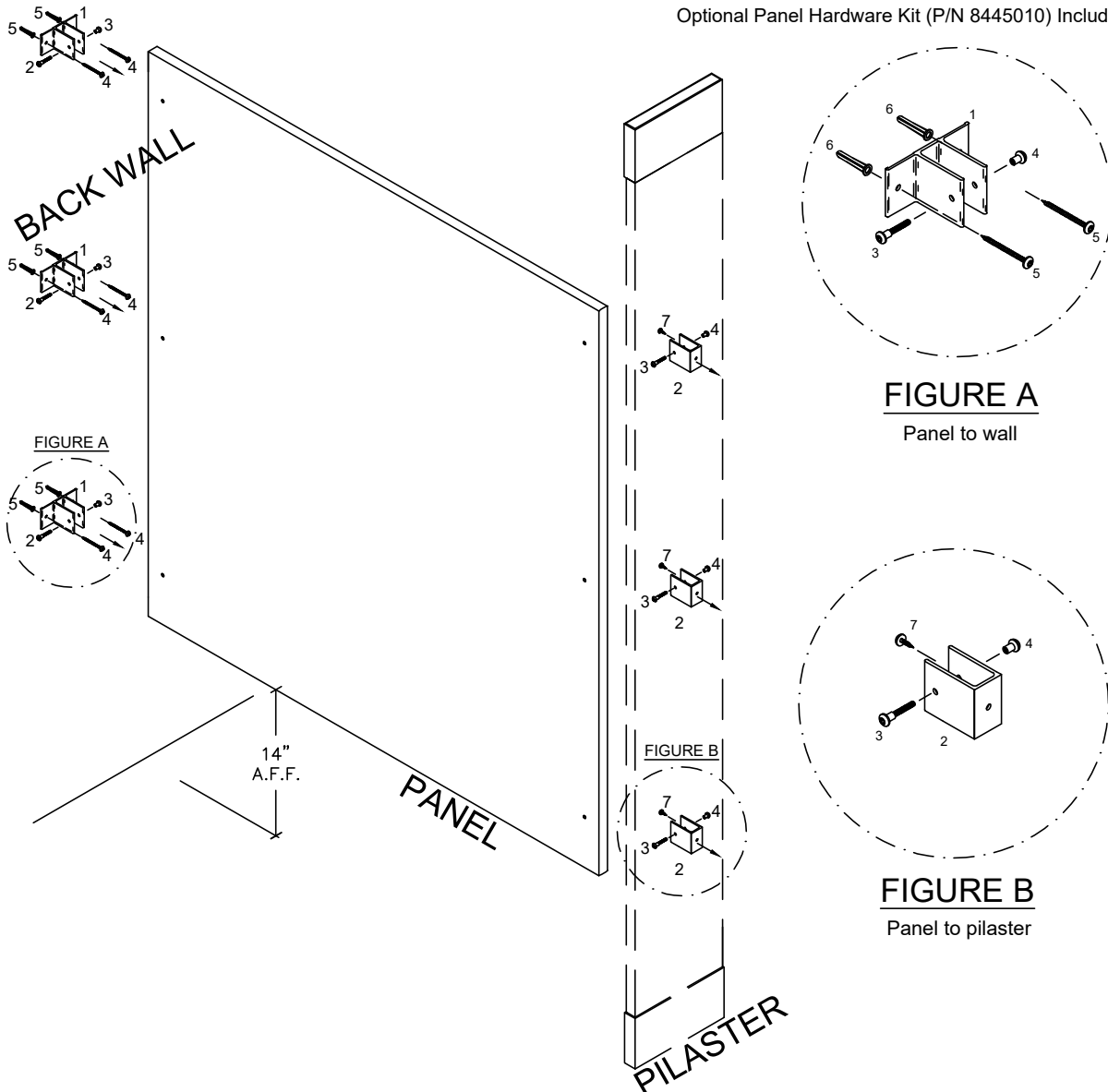

Aluminum Panel Hardware Kit (P/N 8445020) Includes			
PART ID.		DESCRIPTION	QTY
1		One Ear Alum. Bracket	(3)
2		Alum. "U" Bracket	(3)
3		Vandal Resistant 1" Step Bolt	(6)
4		Vandal Resistant 5/8" Barrel Nut	(6)
5		Vandal Resistant 2-1/2" Screw	(6)
6		Plastic Shield	(6)
7		Vandal Resistant 5/8" Screw	(3)

Optional Panel Hardware Kit (P/N 8445010) Includes: (1) Ear brackets



**FLOOR ANCHORED/CEILING ANCHORED
ANCHORED PILASTER/WALL
ASSEMBLY
POLYMER**





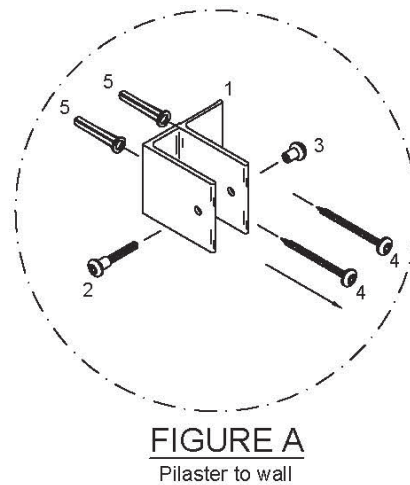
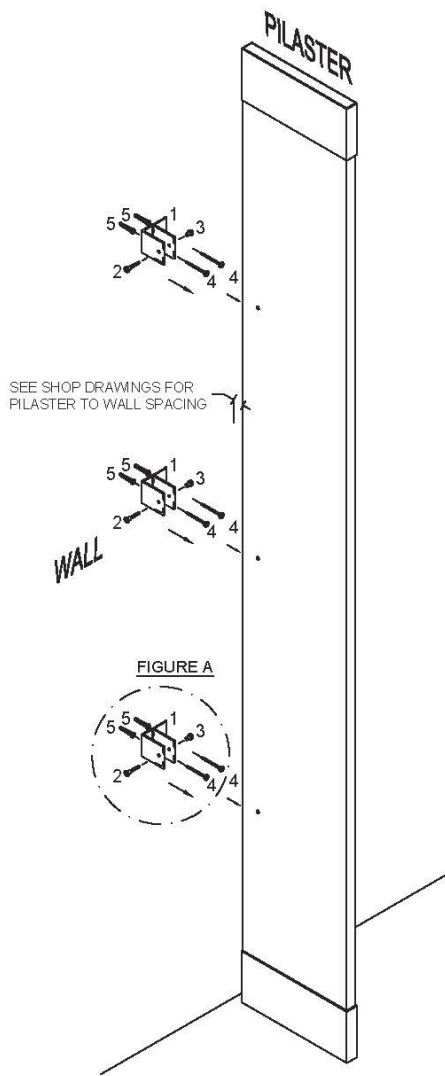

Plumb pilaster and fasten pilaster to wall brackets using through bolts.

Pilaster/Wall Hardware Kit (P/N 8445210) Includes: ALUMINUM			
PART ID.		DESCRIPTION	QTY
1		One Ear Wall Bracket	(3)
2		Theft Resistant S/S Step Bolts 1" Long	(3)
3		Theft Resistant S/S Barrel Nut	(3)
4		Theft Resistant S/S #14 x 2 1/2" S.M.S	(6)
5		Plastic Shields	(6)
6		Theft Resistant S/S #14 x 3/4" S.M.S	(6)



**FLOOR ANCHORED/CEILING ANCHORED
PILASTER/PANEL ALCOVE
ASSEMBLY
POLYMER**





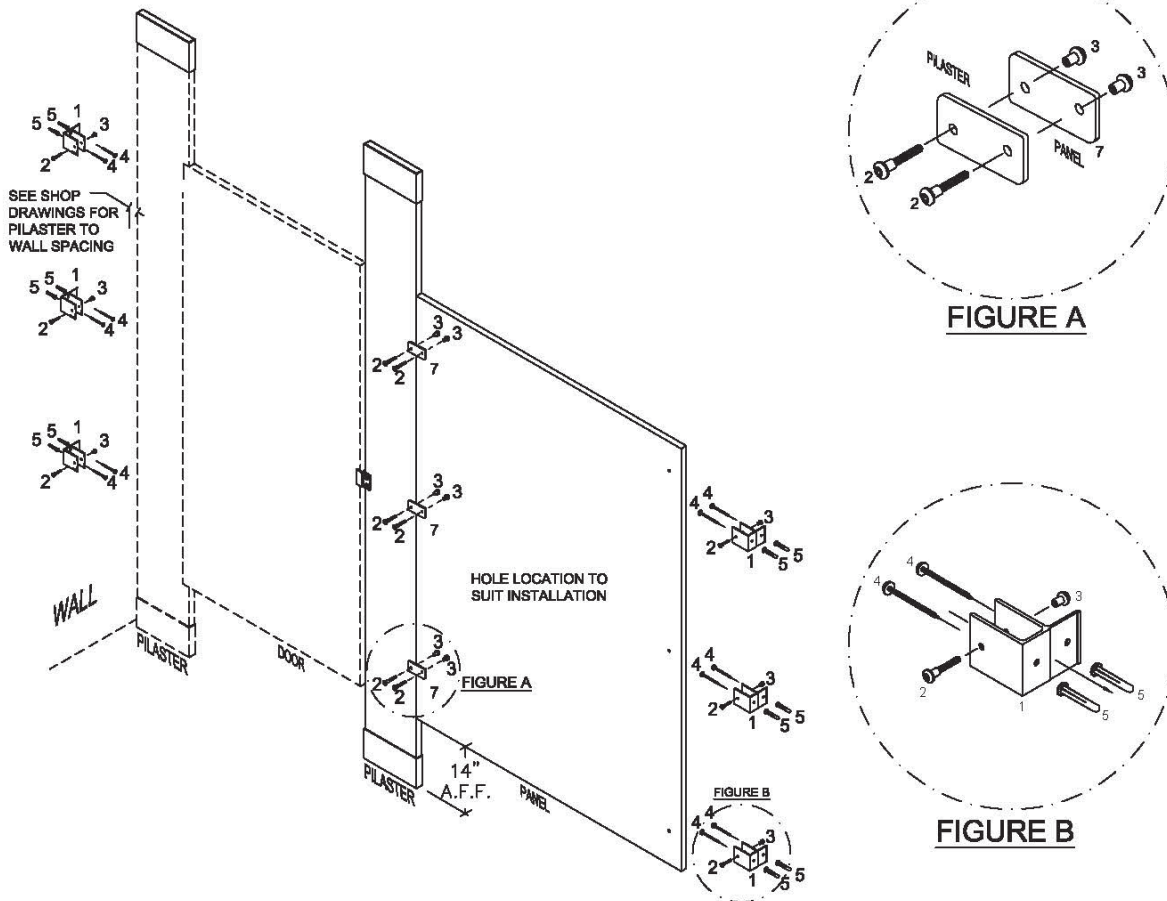

Optional #8447020 2-ear alcove kit.

Panel Hardware Kit (P/N 8447010) Includes: ALUMINUM			
PART ID.		DESCRIPTION	QTY
1		One Ear Alum. Bracket	(6)
2		Vandal Resistant S/S 1" Step Bolts	(12)
3		Vandal Resistant S/S 5/8" Barrel Nut	(12)
4		Vandal Resistant S/S 2 1/2" S.M.S	(14)
5		Plastic Shields	(14)
6		Vandal Resistant 3/4"	(3)
7		Alcove Clip S/S	(6)



NOTE:
There will be no gap between in-line panel and pilaster.

PANEL TO PILASTER/WALL
ASSEMBLY FULL HEIGHT BRACKET

Panel Hardware Kit (P/N 8466020) Includes: ALUMINUM FULL HEIGHT		
PART ID.	DESCRIPTION	QTY
1	 Two Ear Bracket	(1)
2	 "U" Bracket	(1)
3	 Vandal Resistant S/S Step Bolts 1" Long	(12)
4	 Vandal Resistant S/S Barrel Nut	(12)
5	 Vandal Resistant S/S 2 1/2" S.M.S	(12)
6	 Plastic Shields	(12)
7	 Vandal Resistant S/S 5/8" S.M.S	(12)

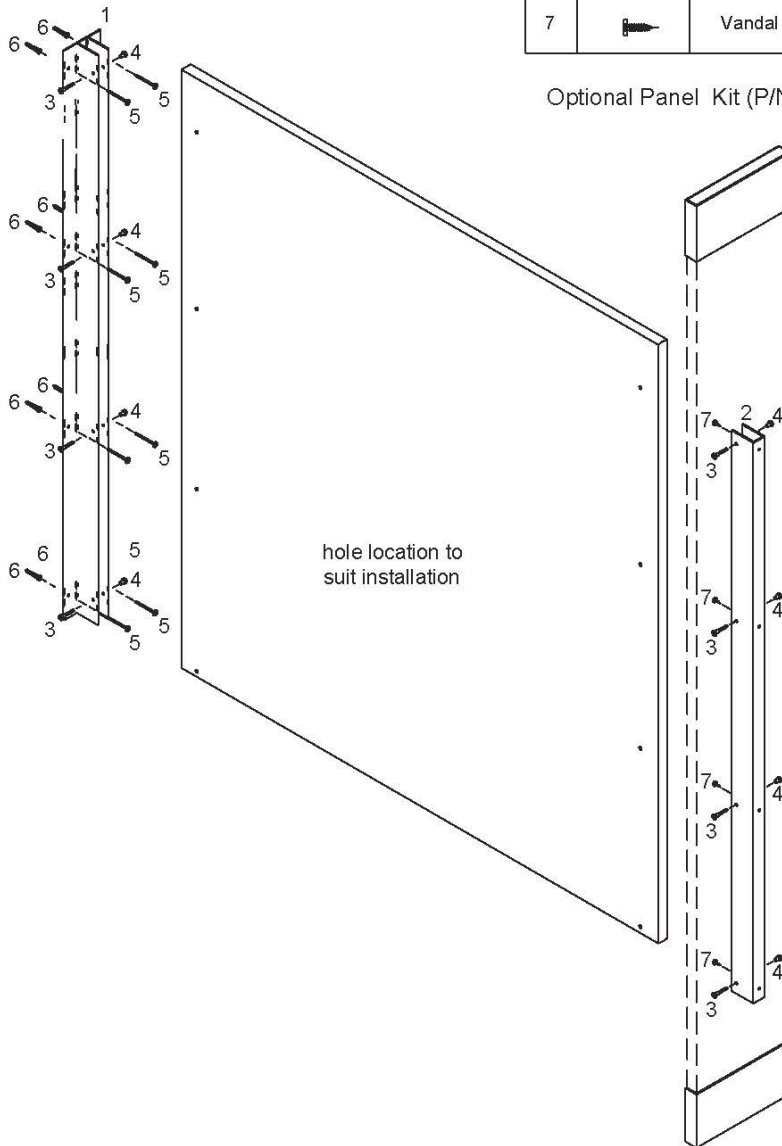

Optional Panel Kit (P/N 8466010) Includes: (1) Ear Bracket

PANEL TO PILASTER/WALL
ONE EAR ASSEMBLY
FULL HEIGHT BRACKET

Pilaster/Wall Hardware Kit (P/N 8466210) Includes: ALUMINUM FULL HEIGHT			
PART ID.		DESCRIPTION	QTY
1		One Ear Wall Bracket	(1)
2		Vandal Resistant S/S Step Bolts 1 1/4" Long	(6)
3		Vandal Resistant S/S Barrel Nut	(6)
4		Vandal Resistant S/S 2 1/2" S.M.S	(12)
5		Plastic Shields	(12)

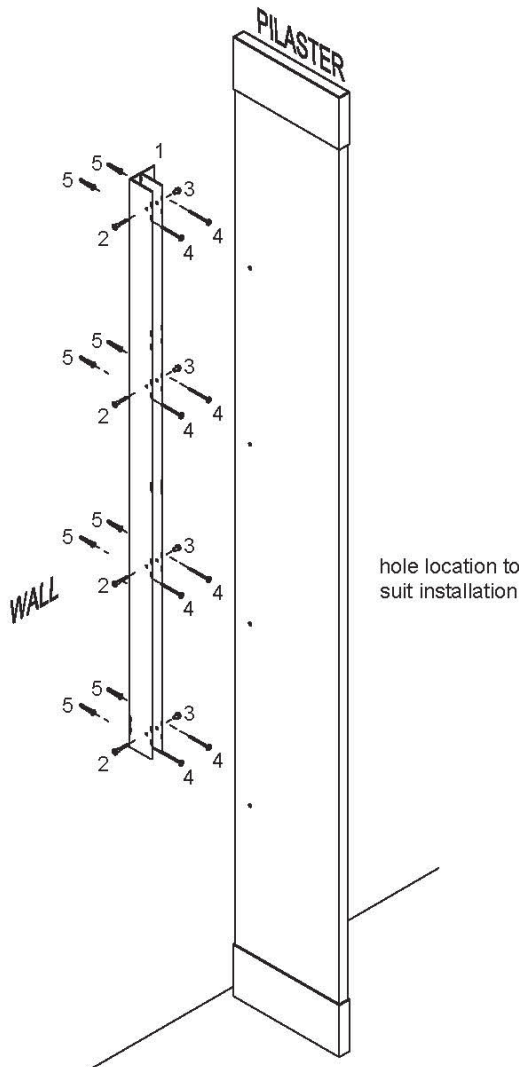

**CARE AND MAINTENANCE OF
TOILET PARTITIONS**

In order to provide toilet partitions with the care and maintenance, the following instructions must be followed.

- A. All surfaces must be kept clean with water and a mild soap solution only.
- B. In order to provide toilet partitions with the proper care and maintenance, the above instructions must be followed.

WARNING

Under no circumstances should these components be subjected to:

- *Abrasive powders or pads
- *Water closet cleaners
- *Ceramic tile cleaners
- *Solutions containing more than 1% by volume of ammonia
- *Solutions containing acids or lye
- *Solutions containing enzymes

Attention to work progress during new construction or renovation is important.
Other trades and cleaning services may use agents for ceramics and tiles that will damage these components