

Partition Stalls

Installation Instructions for Maximum Privacy Floor to Ceiling Partitions

☎ 646-453-4564

✉ info@partitionstalls.com

🌐 www.partitionstalls.com



INSTALLATION INSTRUCTIONS FOR
MAXIMUM PRIVACY
FLOOR TO CEILING PARTITIONS

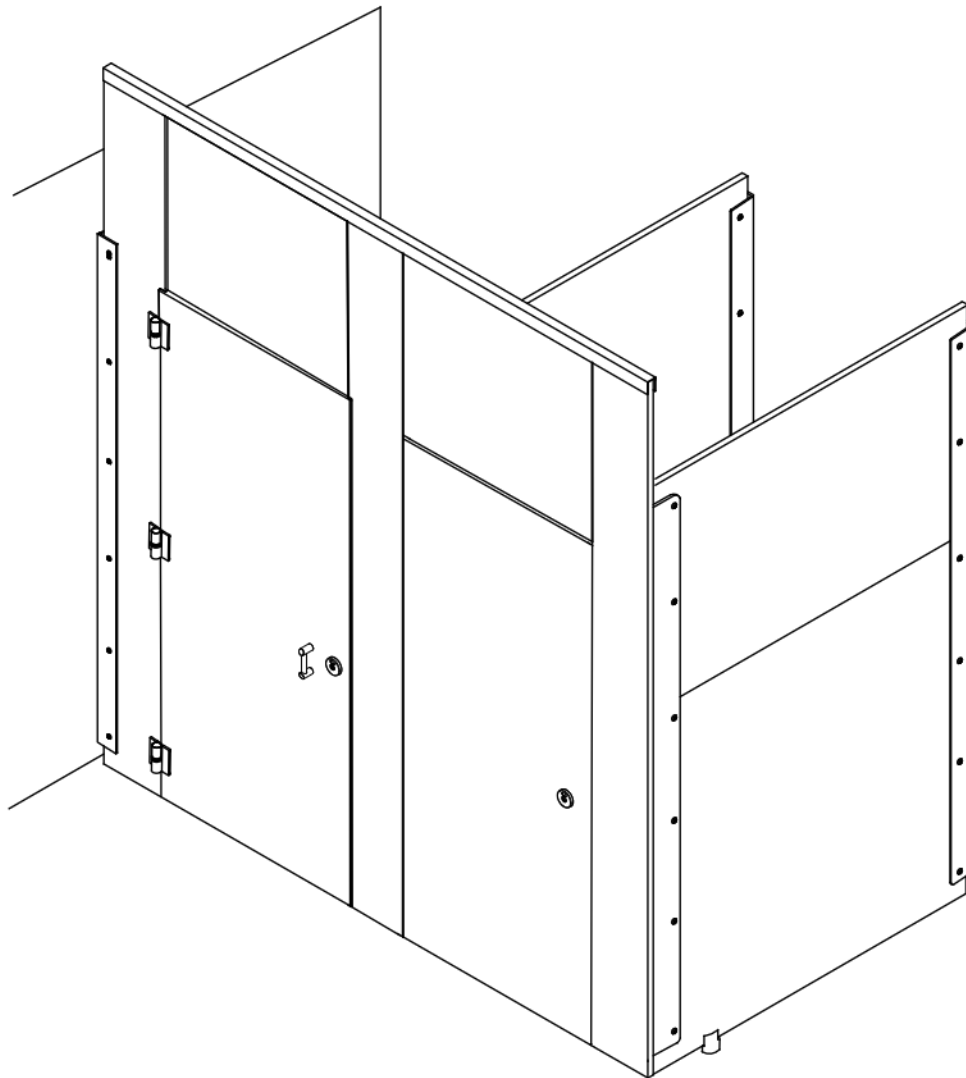

www.asi-globalpartitions.com

(706) 827-2700



www.asi-accuratepartitions.com

(708) 442-6800



COLOR: ADVISE

DIRECTIONAL PATTERN - PANELS WILL RUN PERPENDICULAR TO PATTERN ON COMPARTMENT FRONTS.

○ = PEDESTAL
 ☒ = BLOCKING

A TYPICAL FLOOR TO CEILING MAXIMUM PRIVACY ELEVATION

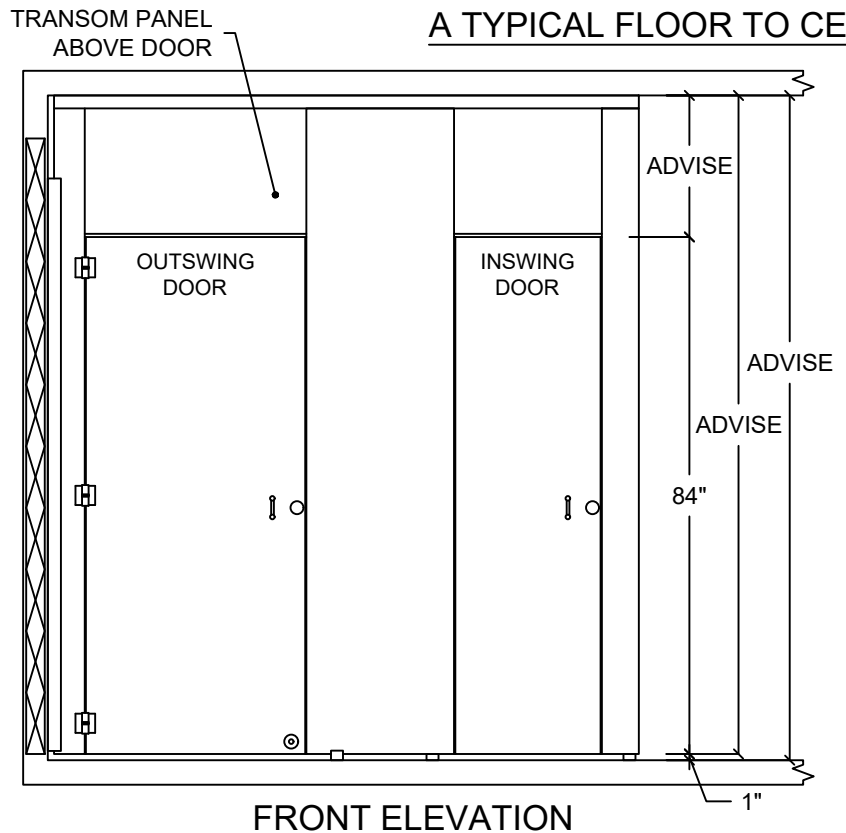

FRONT ELEVATION

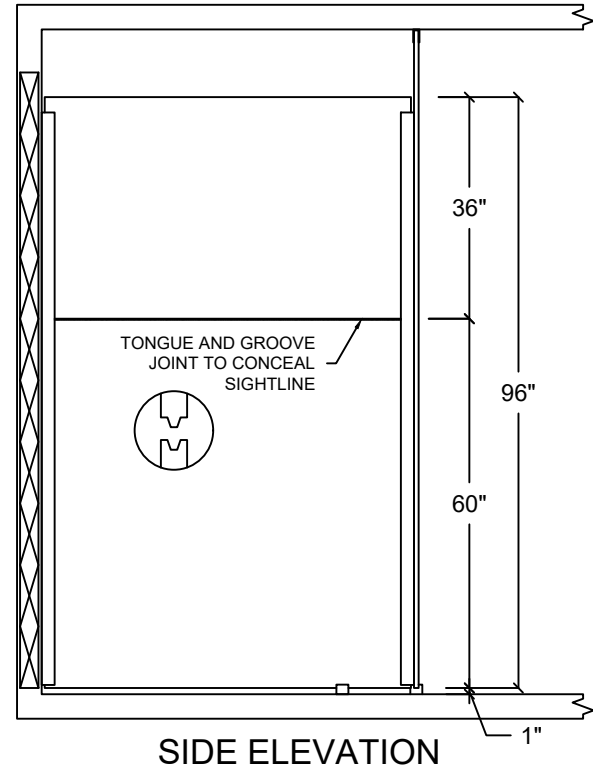

SIDE ELEVATION

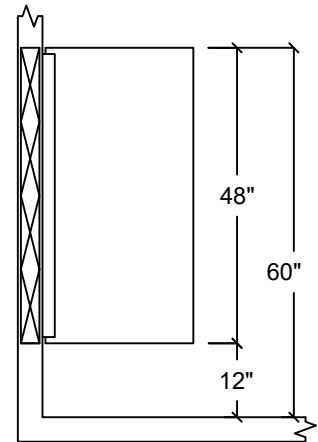

SCREEN SIDE ELEVATION

- NOTES:**
1. 1/2" THICK PANELS
 2. 3/4" THICK PILASTERS & DOORS
 3. ANODIZED BLACK INDICATOR LATCH
 4. ROUTED DOORS & PILASTERS (NO-SIGHTLINE SYSTEM)
 5. ANODIZED BLACK CONTINUOUS BRACKETS
 6. ANODIZED BLACK HEADRAIL
 7. ALL FASTENERS ARE TAMPER RESISTANT
 8. 2" MINI. STRUCTURAL CONCRETE REQ'D
 9. ALL DIMENSIONS ARE IN INCHES
 10. DOORS - 3 BARREL HINGES PER DOOR

FEDERAL ADA TOE CLEARANCE GUIDELINE
604.8.1.4 Toe Clearance. The front partition and at least one side partition shall provide a toe clearance of 9 inches minimum above the finish floor and 6 inches deep minimum beyond the compartment-side face of the partition, exclusive of partition support members. Compartments for children's use shall provide a toe clearance of 12 inches minimum above the finish floor.

EXCEPTION: Toe clearance at the front partition is not required in a compartment greater than 62 inches deep with a wall-hung water closet or 65 inches deep with a floor-mounted water closet. Toe clearance at the side partition is not required in a compartment greater than 66 inches wide. Toe clearance at the front partition is not required in a compartment for children's use that is greater than 65 inches deep.



JOB:		P.O. #		S.O.#FC	
DIST:	LOC:	DWG #: 1	DATE:	DRAWN BY:	SHEET: 1 OF 1

Table of Contents

Please review full instructions before starting installation.

<u>Topic</u>	<u>Page</u>
Step 1 & 2 Layout & Bracket installation.....	4
Step 3 Headrail to Ceiling Connections.....	5
Step 4 Pedestal installation	6
Valence panel / valence connectors prep for installation	7
Step 5 Pilaster/Wall Assembly	8
Panel/Wall Assembly	9
Step 6 Pilaster Preparation & Step 7 Securing Pilaster.....	10
Valence panel / valence Connectors installation	11
Pilaster/Panel Alcove Bracket Assembly.....	12
Step 8 Headrail to Ceiling Connections (Continued)	13
Door Hardware Inswing Assembly.....	14
Door Hardware Outswing Assembly	15
Indicator Latch Assembly	16

Table of Contents

<u>Topic</u>	<u>Page</u>
Hinge Assembly	17
Urinal Screen Installation	18
Care & Maintenance	19

Required Tools

- Power Drill
- T-27 Pin Torx Driver
- 3/16” Masonry Drill Bit
- 1” support as required
- 4mm Hex Wrench
- 1/4”, #11/64 & 9/64” Drill Bits (and others as needed)
- Drill Bit Stop
- 4’ (or longer) Level
- 3/32” Hex Wrench

Optional Tools

- Construction Jacks
- Grabo Vacuum Lifter



Important

The Components for this project have been custom fabricated. They are guaranteed with respect to manufacture and workmanship and were inspected at the factory.

Before beginning work, the units should be inspected. If damage occurred in transit, report immediately to the freight company or other agencies that may have caused the damage.

www.asi-globalpartitions.com

(706) 827-2700



www.asi-accuratepartitions.com

(708) 442-6800



STEP 1:
LAYOUT

- A. Before proceeding, confirm that the backings of the walls, ceiling and floor are adequate to support the secure mounting of the MAXIMUM PRIVACY units.
- B. Review the layout drawings and package lists that have accompanied this order.
- C. Establish and mark center lines for wall brackets, headrail and pedestals. See the accompanied fabrication drawings for compartment dimensions.
- D. Mark wall bracket holes using the brackets as templates. the bottom of the bracket should sit at 1 1/2", above the floor.
- E. Mark pedestal holes no more than 10" from the front of the panel.
- F. Mark the location of the headrail on the ceiling.

CENTER LINE FOR
CEILING CONNECTIONS

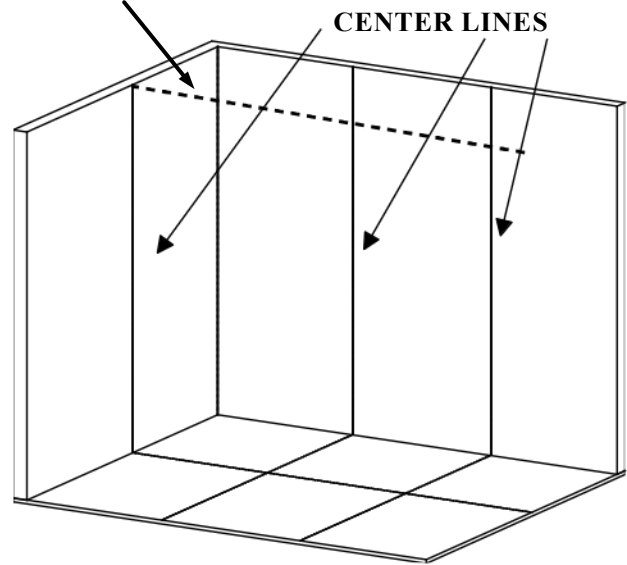

Note: ASI recommends starting at one end and installing one compartment one at a time to allow for field adjustments as needed.

STEP 2:
WALL BRACKETS

- A. Drill 1/4" diameter x 2 1/2" minimum deep holes for the red plastic shields provided using a 1/4" drill bit. However, as site conditions vary, an assortment of bit sizes is recommended.
- B. Insert the anchoring devices into the walls, and secure the wall brackets with #12 X 2 1/2 screws.

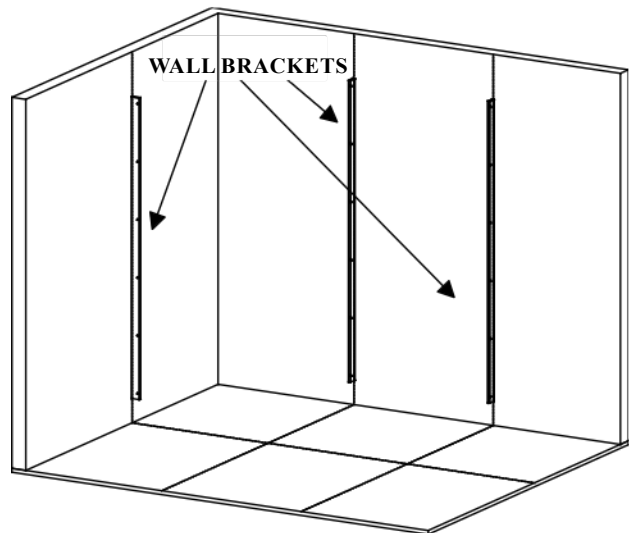

STEP 3:
HEADRAIL TO CEILING CONNECTIONS

- A. Cut headrail to suit.
- B. Paint exposed ends using provided touch up paint.
- C. Using 1/4" drill bit, drill holes through the top of the headrail no more than 30" apart. These holes should align with the blocking in the ceiling.
- D. Using the headrail for a template. Drill the pilot holes through the ceiling & into blocking using a 9/64" drill bit.

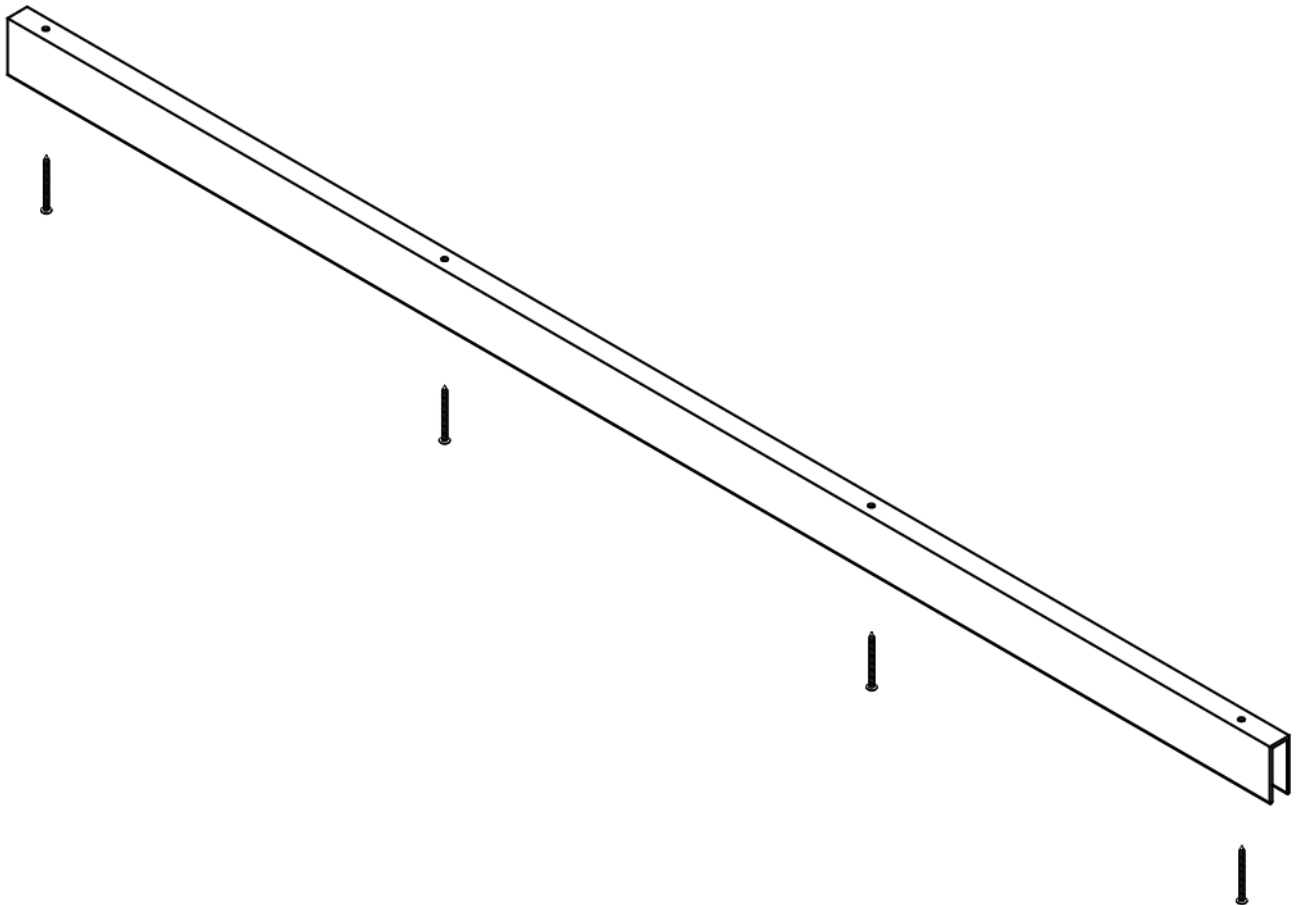

STEP 4:
PEDESTAL
INSTALLATION

- A. Using a 3/16" masonry bit drill a hole to a minimum of 2" deep for the pedestal.
- B. Attach base of pedestal to the floor using 1/4" concrete screws.
- C. Assemble pedestal and adjust it to the desired height by turning clockwise or counterclockwise.

Note: The top of all pedestals should be level with one another throughout the room.

Note: The shim is only used under 1/2' panels.

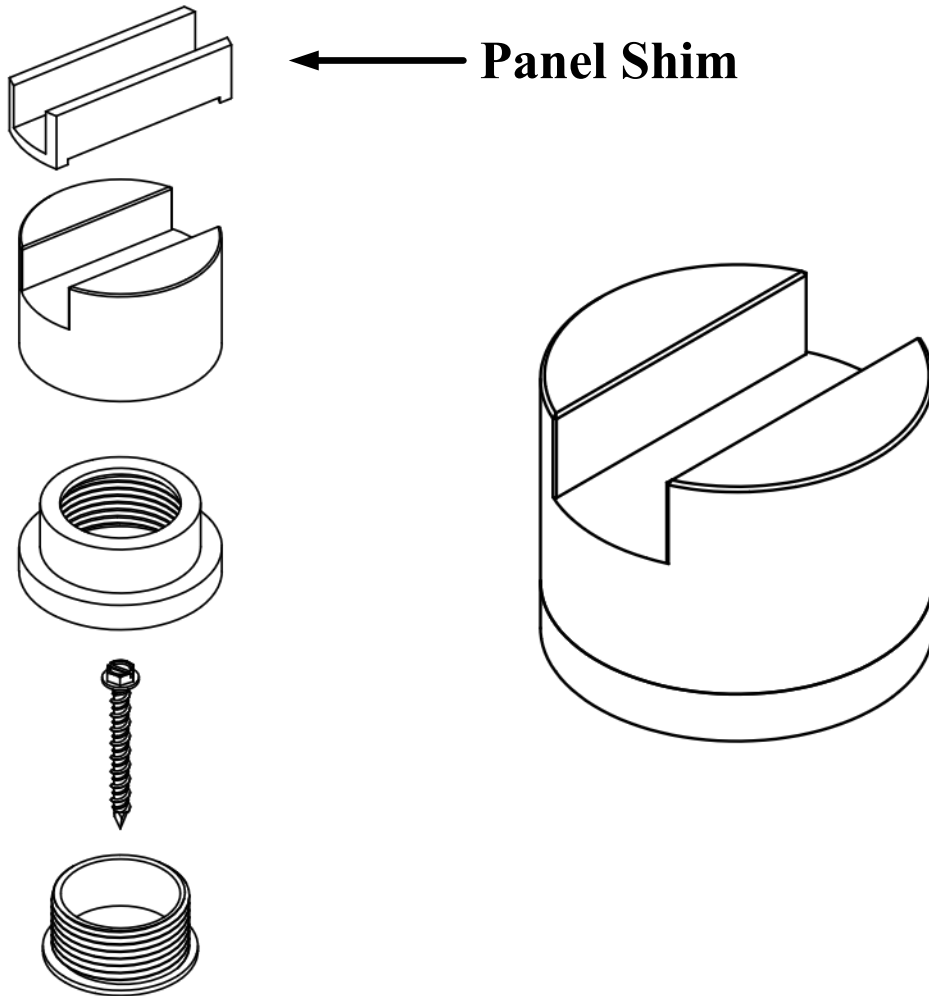

VALENCE PANEL PREPARATION

- A. Insert the valence connector containing the lever in to the ends of the valence panel until seated flush.
- B. Insert the non-levered valence connector in the edge of the pilaster until flush.

Note: The hex adjuster should align with the hole in the valence.

Valences 24" and taller will require 3 valence connectors per end.

**FIGURE A
VALENCE CONNECTOR
TO PILASTER**

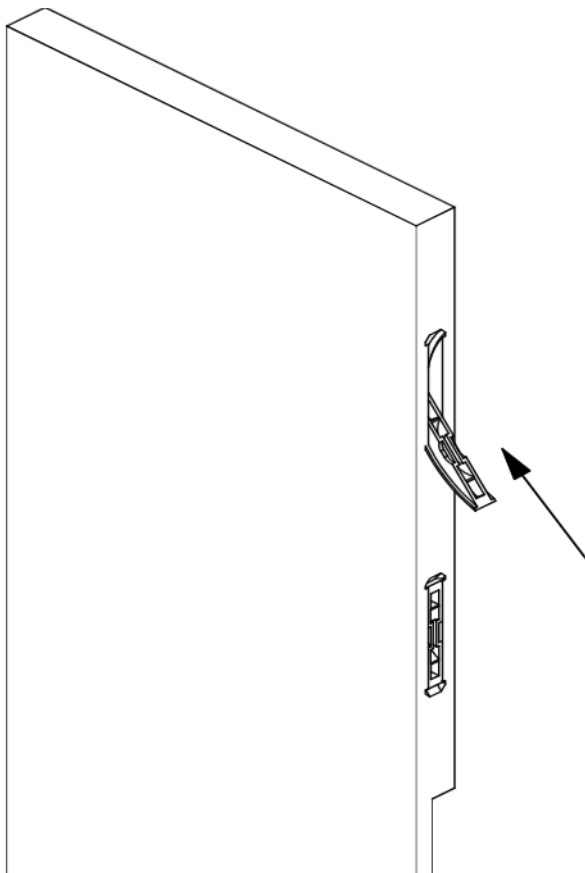

**FIGURE B
VALENCE CONNECTOR
TO VALENCE**

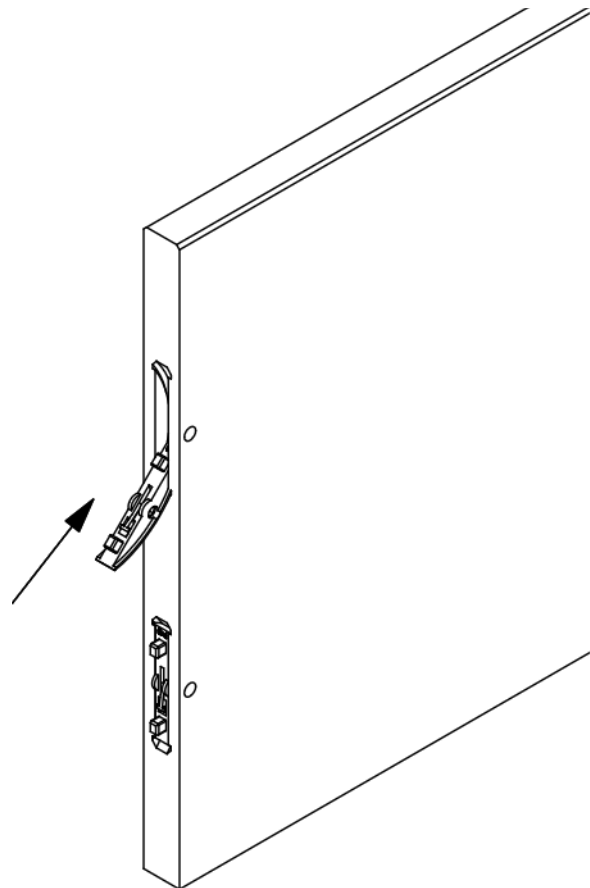

www.asi-globalpartitions.com

(706) 827-2700

ASI Global
Partitions

www.asi-accuratepartitions.com

(708) 442-6800

ASI Accurate
Partitions

STEP 5:
PILASTER TO WALL
ASSEMBLY

PILASTER PREPARATION

- A. Note that each pilaster is labeled and can be matched to the layout based on that label.
- B. Slide pilaster in headrail.
- C. Set the pilaster in the wall bracket. (And on pedestal if required)
- D. Level the pilaster and adjust the gap between the pilaster and wall.
- E. Using a 1/4" drill bit. Drill through the holes in the bracket.
- F. Fasten the pilaster to the wall bracket using 3/4" bolts & 3/8" nuts.
- G. Drill 11/64" X 3/4" holes approximately 1" from each edge of the pilaster.
- H. Secure headrail using #10 x 5/8" screws.

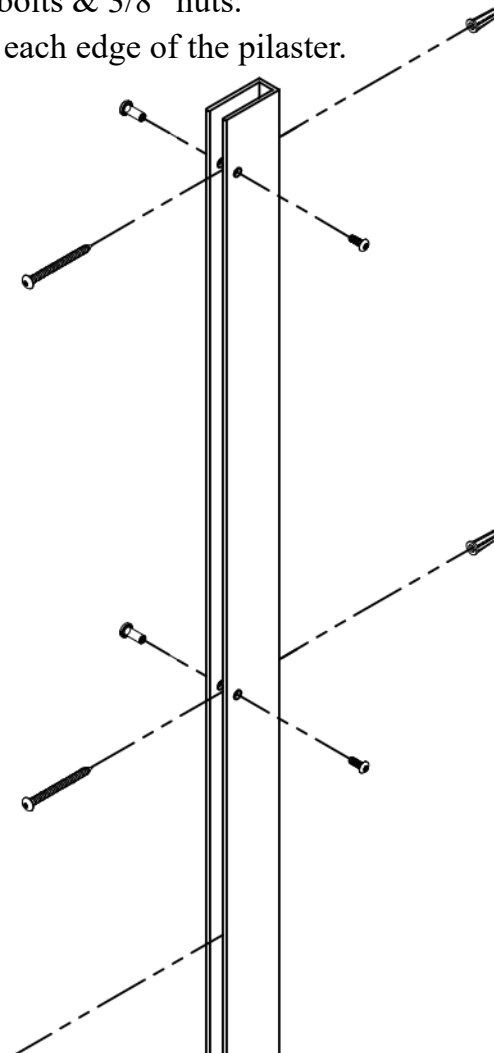
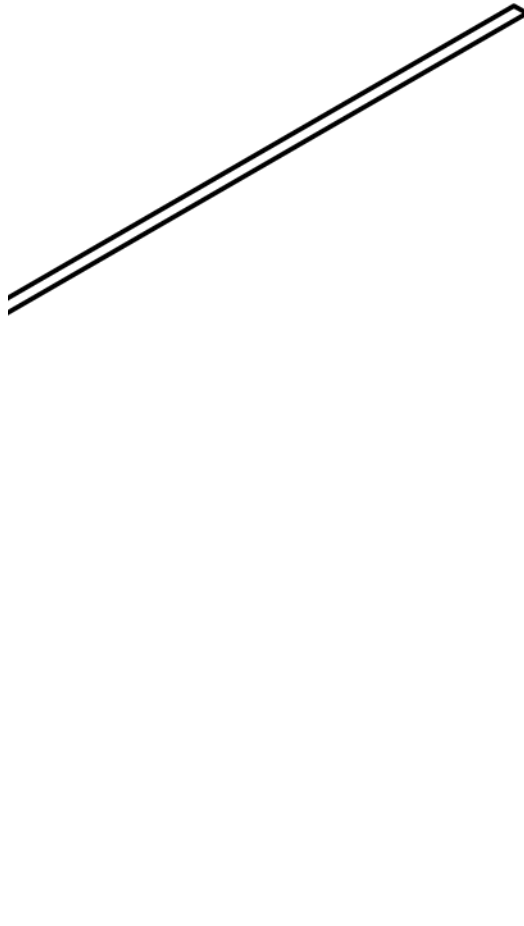

www.asi-globalpartitions.com

(706) 827-2700



www.asi-accuratepartitions.com

(708) 442-6800



PANEL TO WALL
ASSEMBLY

- A. Set the bottom panel in the wall bracket & pedestal.
- B. Level the panel and adjust the gap between the panel and wall bracket.
- C. Using a 1/4" drill bit. Drill through the holes in the bracket.
- D. Fasten the panel to the wall bracket using 1/2" bolts & 5/8" nuts.
- E. Place top panel on top of the bottom panel aligning the tongue & groove edges and slide into the bracket.
- F. Align the front edges of the top and bottom panel.
- G. Fasten the panel to the wall bracket using 1/2" bolts & 5/8" nuts.

Note: The top of all panels should be level with one another throughout the room.

FIGURE A

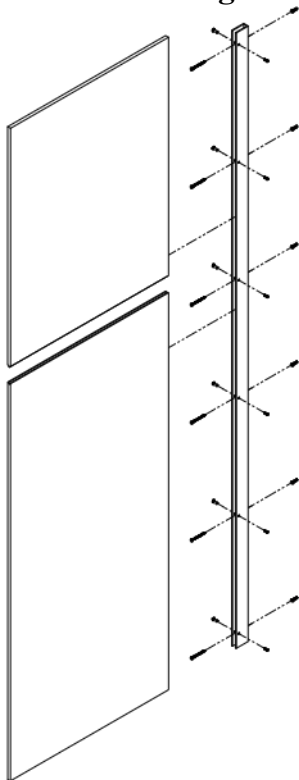
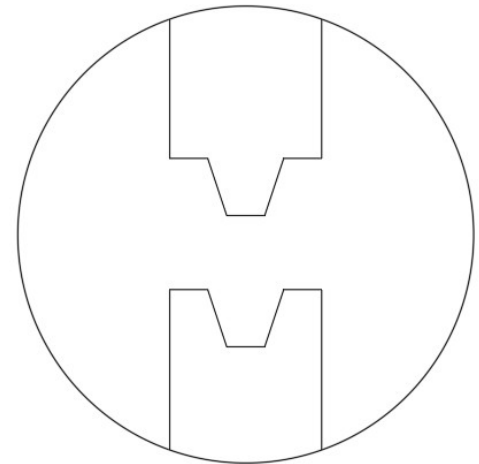

www.asi-globalpartitions.com

(706) 827-2700

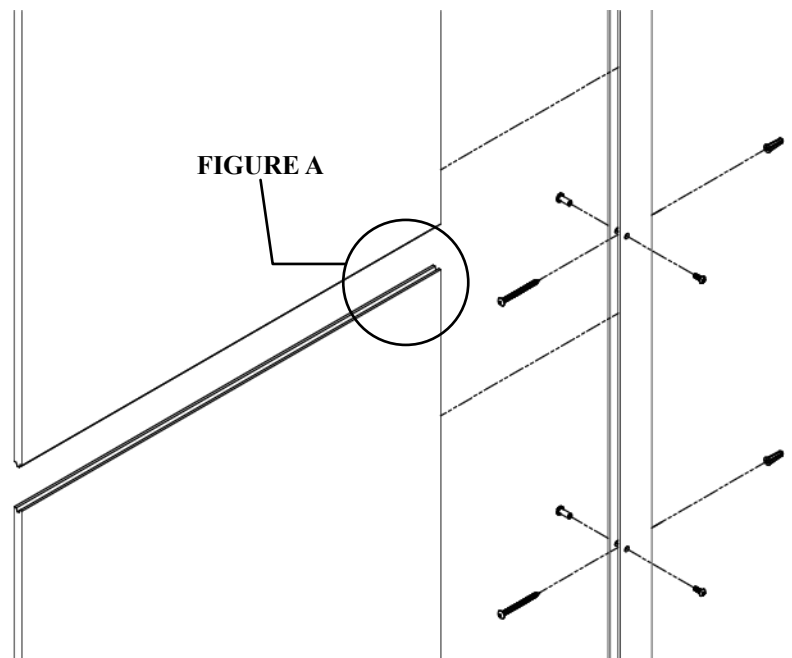

www.asi-accuratepartitions.com

(708) 442-6800



STEP 6:

PILASTER PREPARATION

- A. **Note that each pilaster is labeled and can be matched to the layout based on that label.** Align the U-brackets in position on rear of pilasters. Refer to layout drawings and make sure U-brackets are in alignment with wall brackets.
- B. Mark U-bracket holes using the brackets as templates. Drill 11/64" diameter x 1/2" deep holes for U-bracket fasteners (a #11/64" drill bit and drill bit stop are recommended). **Correct hole diameter and depth is critical.**
- C. Attach bracket to pilaster using #12 x 7/16" screws.

Note: Verify that door opening will be correct before drilling for "U" brackets. Make adjustments if necessary.

FIGURE 7

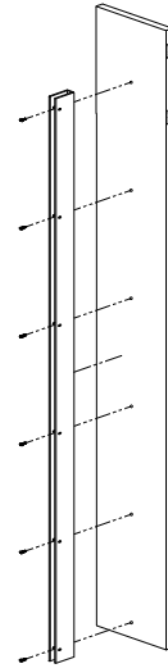

STEP 7:

SECURING PILASTERS

- A. A temporary support device is highly recommend to place under each pilaster to assist in alignment.
- B. Plumb each pilaster and adjust gap between pilaster & panel.
- C. Using a 1/4" drill bit. Drill through the holes in the bracket.
- D. Fasten the bracket to the panel using 1/2" bolts & 5/8" nuts.
- E. Remove the support device.

FIGURE 8

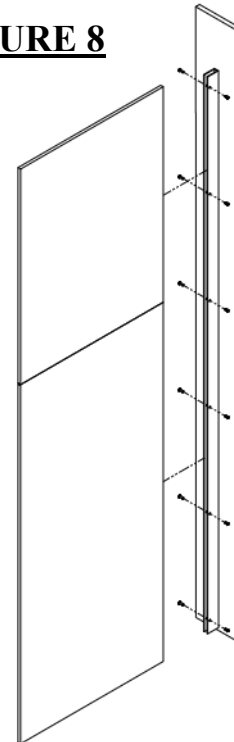

VALENCE PANEL INSTALLATION

- A. Using a 4mm hex wrench, align the valence connectors and turn lever until locked.
- B. Repeat the above process at all pilaster to valence connections.

Note: The holes in the valence should be located inside the compartment.

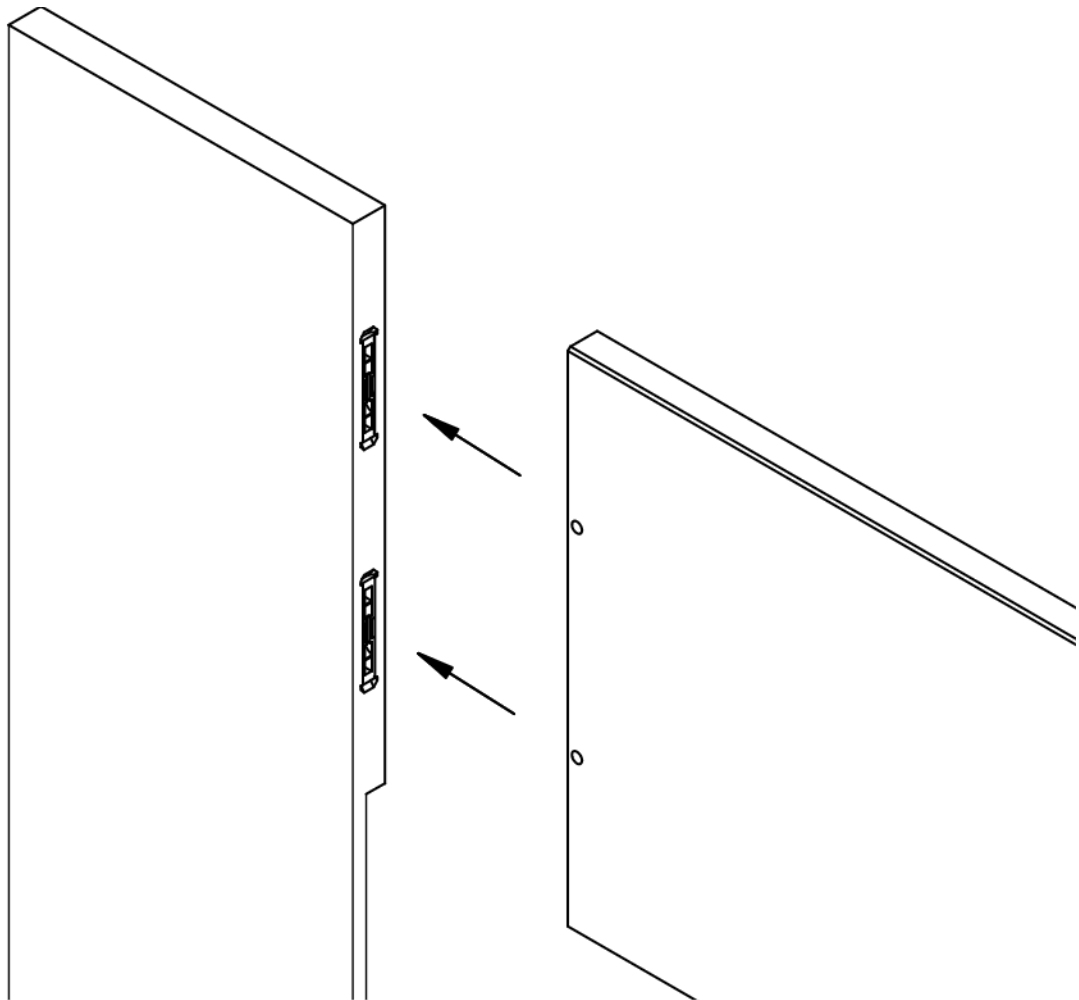

PILASTER/ PANEL ALCOVE

NOTE: The tops of all pilasters must be level with one another prior to securing the pilaster to the panel.

- A. See Pg 8 for pilaster to wall installation.
- B. See Pg 9 for panel to wall installation.
- C. Sit the middle pilaster into the pedestal and butt it against the edge of the panel. Inside the compartment, place the continuous alcove bracket on the panel and pilaster centering it over the seam. Mark the holes, then using an 11/64" drill bit, drill to a minimum depth of 5/8". Attach the alcove bracket to the panel and pilaster using the #10 x 5/8" screws.

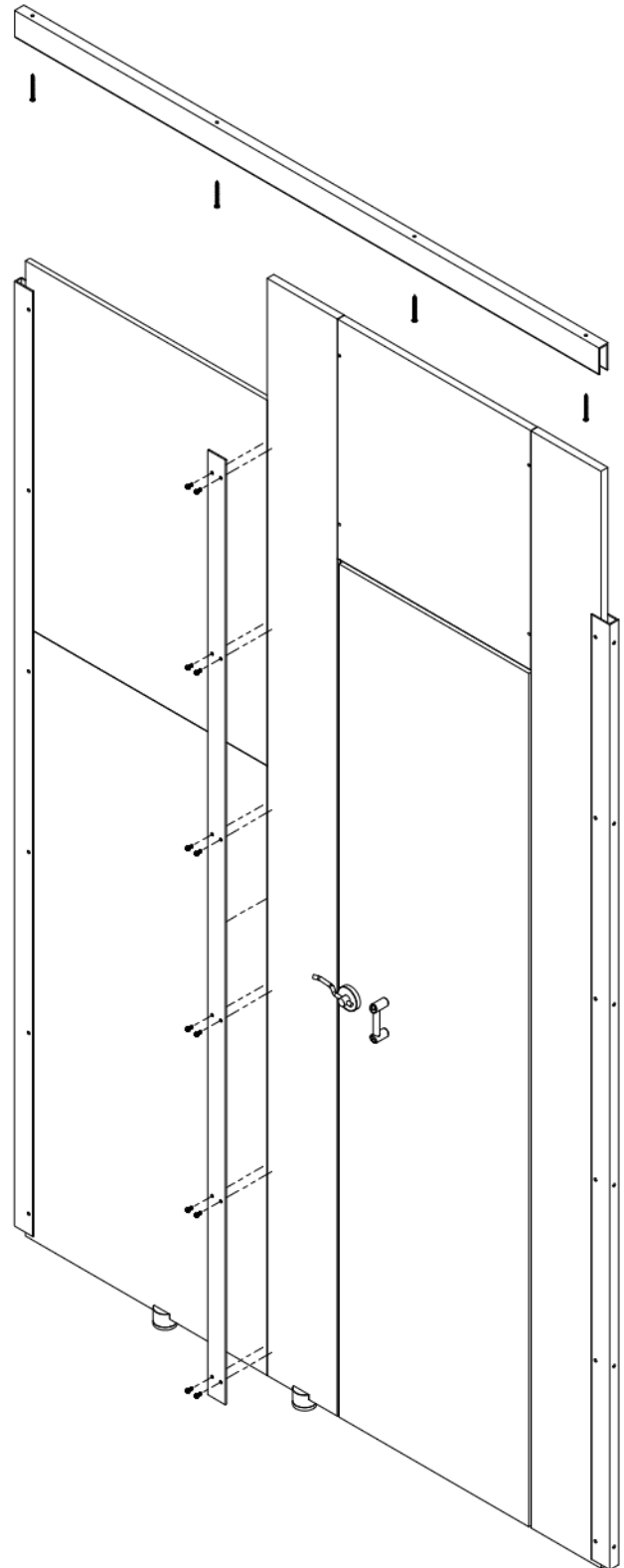

STEP 8:
HEADRAIL TO CEILING CONNECTIONS (CONTINUED)

- A. Once aligned, drill 11/64" & 3/4" holes approximately 1" from each edge of the pilaster and valence.
- B. Secure headrail using #10 x 5/8" screws.

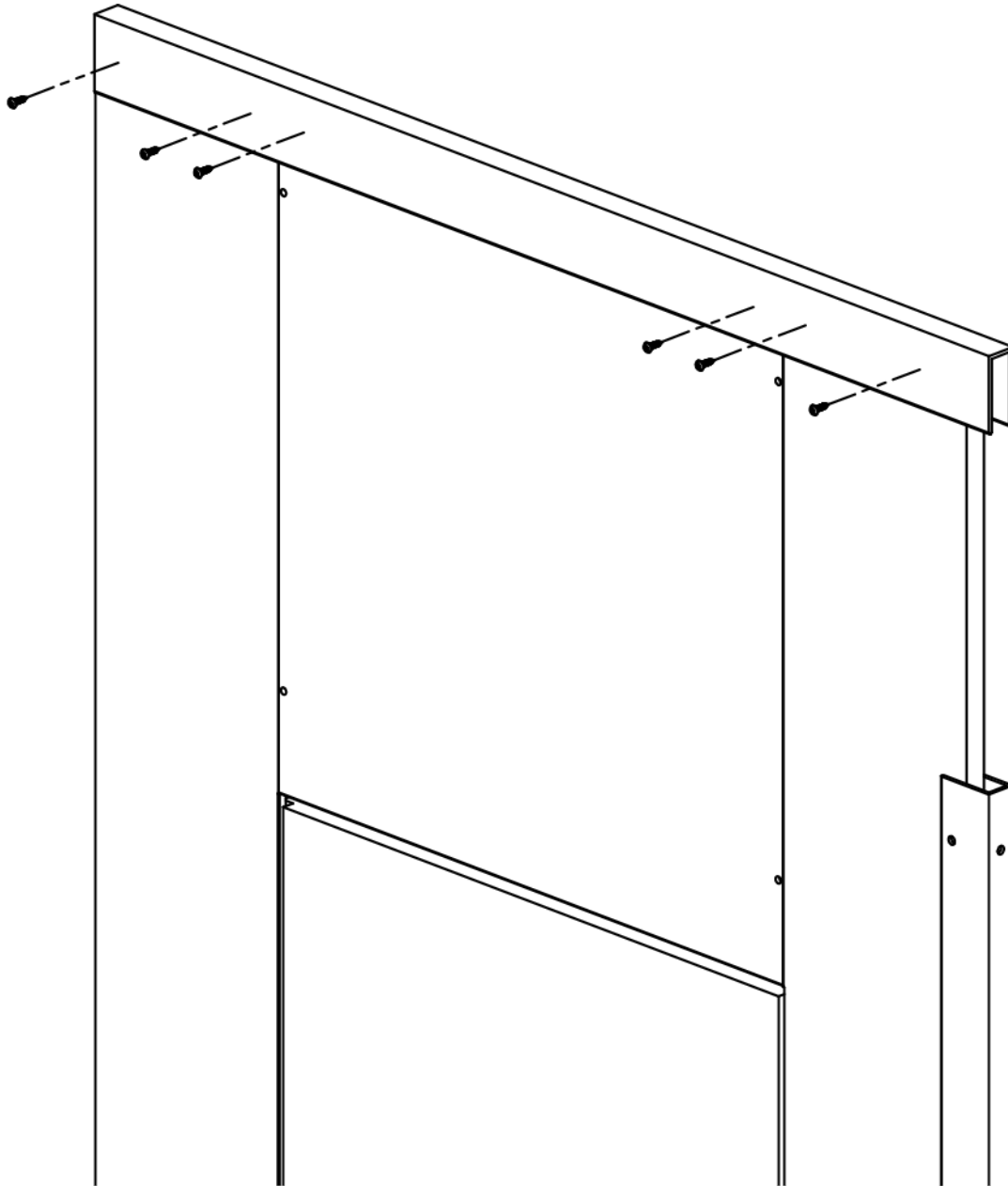

www.asi-globalpartitions.com

(706) 827-2700

ASI Global
Partitions

www.asi-accuratepartitions.com

(708) 442-6800

ASI Accurate
Partitions

DOOR HARDWARE

INSWING - ASSEMBLY

Note that each Door is labeled and can be matched to the layout based on that label. The hinge and latch holes have been predrilled by the manufacturer. Correct hole diameter and depth is very critical for correct installment.

- A. Place door on temporary support device. Attach the hinges to the pilaster & door using the #10 x 3/4" screws. Remove the support device. (See Pg 17 for the hinge assembly detail.)
- B. Install the latch. (See page 16 for the latch assembly detail.)
- C. Align the keeper with the latch bar near the edge of the pilaster. Using the keeper as a template, mark the hole locations. Using an 11/64" drill bit, drill the keeper holes to a minimum depth of 5/8". Attach the keeper using #10 x 5/8" screws.
- D. Using pliers, gently remove the pin from the end of the coat hook. Remove the escutcheon. Place the coat hook on the door at the desired height. Be sure to verify that the coat hook will strike the panel/wall before the corner of the door. Mark the holes, then using an 11/64" drill bit, drill to a minimum depth of 7/16". Attach the coat hook to the door using the #10 x 1/2" screws. Reinstall the escutcheon and snap it tightly against the door. Reinsert the pin to the top end of the coat hook.
- E. Using the door pull as a template, mark the holes, then using an 11/64" drill bit, drill to a minimum depth of 7/16". Attach the door pull to the door using the #10 x 5/8" screws.

Note that coat hooks and door pulls for ADA doors must be installed no higher than 48" above the finished floor. See Pg 15 for pass through door pull installation instructions.

KEEPER ASSEMBLY

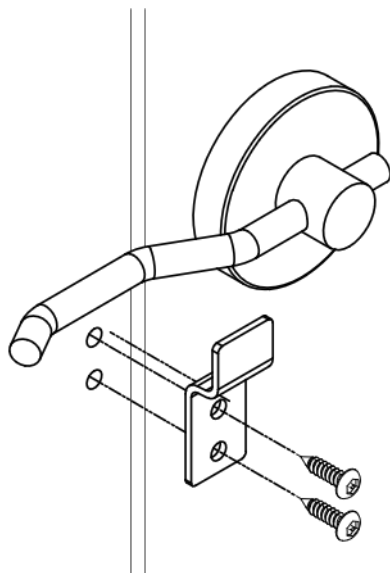

**KEEPER
ASSEMBLY**

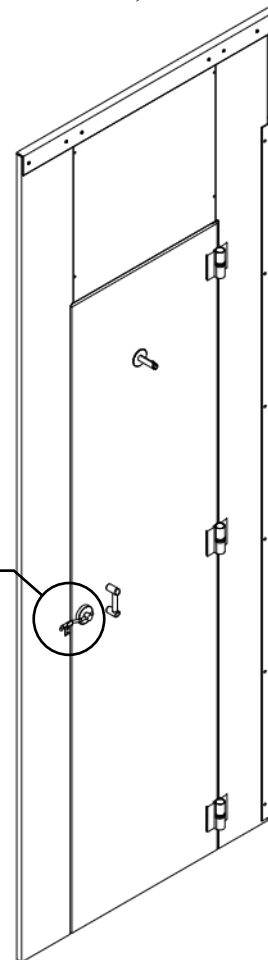

www.asi-globalpartitions.com

(706) 827-2700

www.asi-accuratepartitions.com

(708) 442-6800

DOOR HARDWARE OUTSWING - ASSEMBLY

Note that each Door is labeled and can be matched to the layout based on that label.

The hinge and latch holes have been predrilled by the manufacturer.

Correct hole diameter and depth is very critical for correct installment.

A. Place door on temporary support device. Attach the hinges to the pilaster & door using the #10 x 3/4" screws. Remove the support device. (See Pg 17 for the hinge assembly detail.)

B. Install the latch. (See page 16 for the latch assembly detail.)

Note that the keeper is not required for outswing doors.

C. Using pliers, gently remove the pin from the end of the coat hook. Remove the escutcheon. Place the coat hook on the door at the desired height. Be sure to verify that the coat hook will strike the panel/wall before the corner of the door. Mark the holes, then using an 11/64" drill bit, drill to a minimum depth of 7/16". Attach the coat hook to the door using the #10 x 1/2" screws. Reinstall the escutcheon and snap it tightly against the door. Reinsert the pin to the top end of the coat hook.

D. Repeat step C if installing an additional coat hook as an outswing bumper.

E. Using the door pull as a template, mark the holes, then using an 1/4" drill bit, drill through the door. Attach the door pull to the door using 1-1/2" bolts.

Note that coat hooks and door pulls for ADA doors must be installed no higher than 48" above the finished floor.

LATCH ASSEMBLY

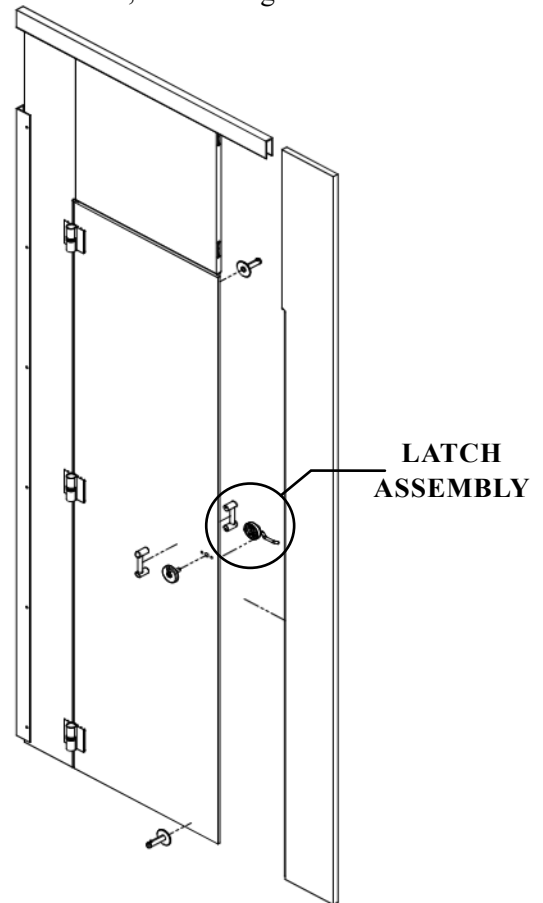
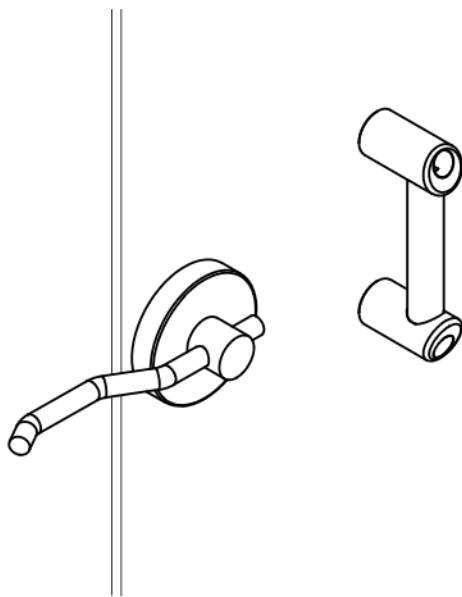

www.asi-globalpartitions.com

(706) 827-2700

www.asi-accuratepartitions.com

(708) 442-6800

INDICATOR LATCH ASSEMBLY

Press the latch handle and the indicator dial placement sleeve into the predrilled holes in the door. Insert the M5 x 25mm bolts through the door and tighten. Turn the handle to the latched position. With the red portion on top, press the center shaft of the indicator dial into the latch. Align the indicator cover and press together on each side of the door until you hear a click.

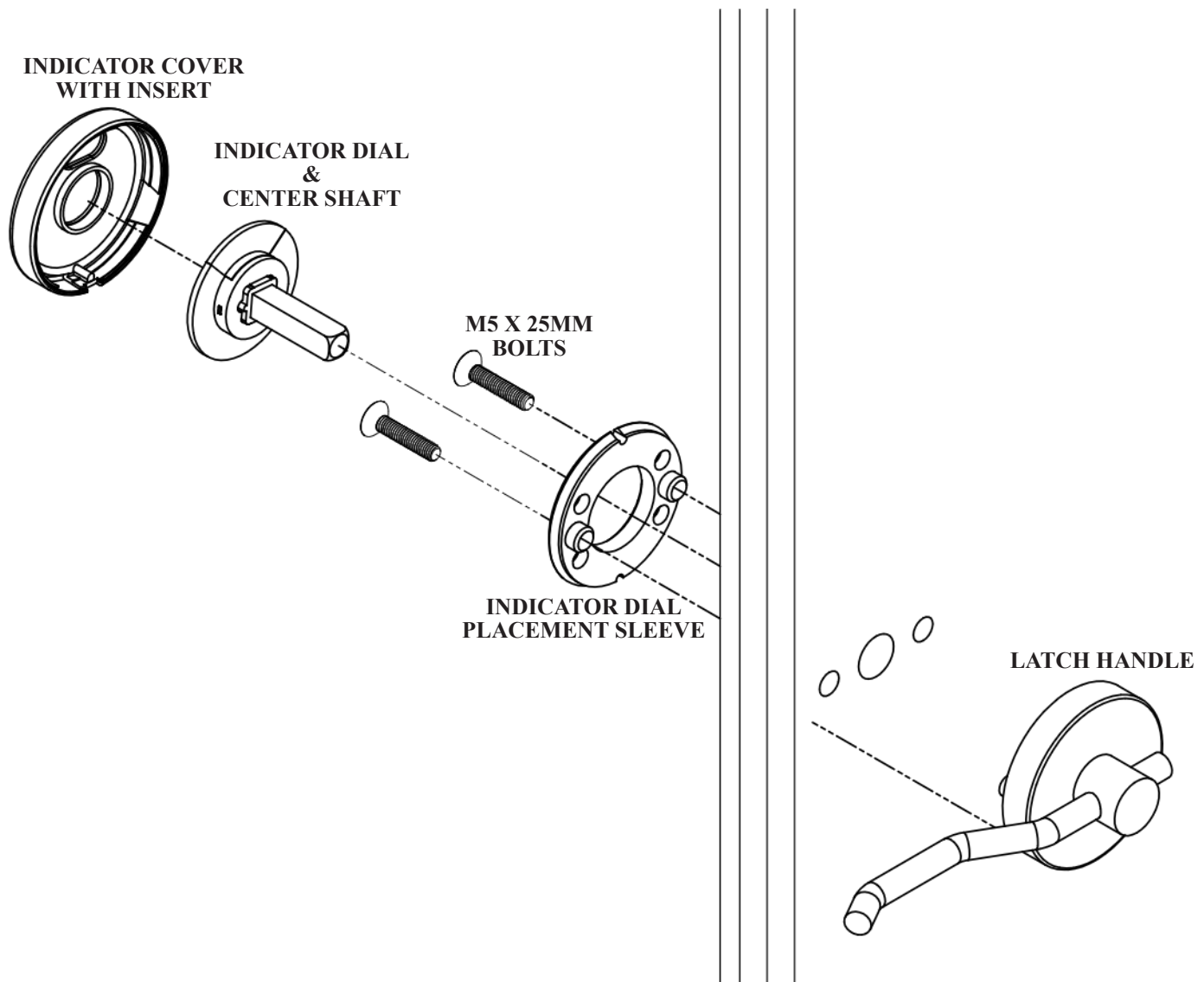

www.asi-globalpartitions.com

(706) 827-2700

www.asi-accuratepartitions.com

(708) 442-6800

HINGE ASSEMBLY

Align hinges with the predrilled holes in the pilaster and door.

Attach using #10 x 3/4" screws.

Slide the cover plate on from the outside edge.

Tighten set screw with a 3/32" Hex wrench.

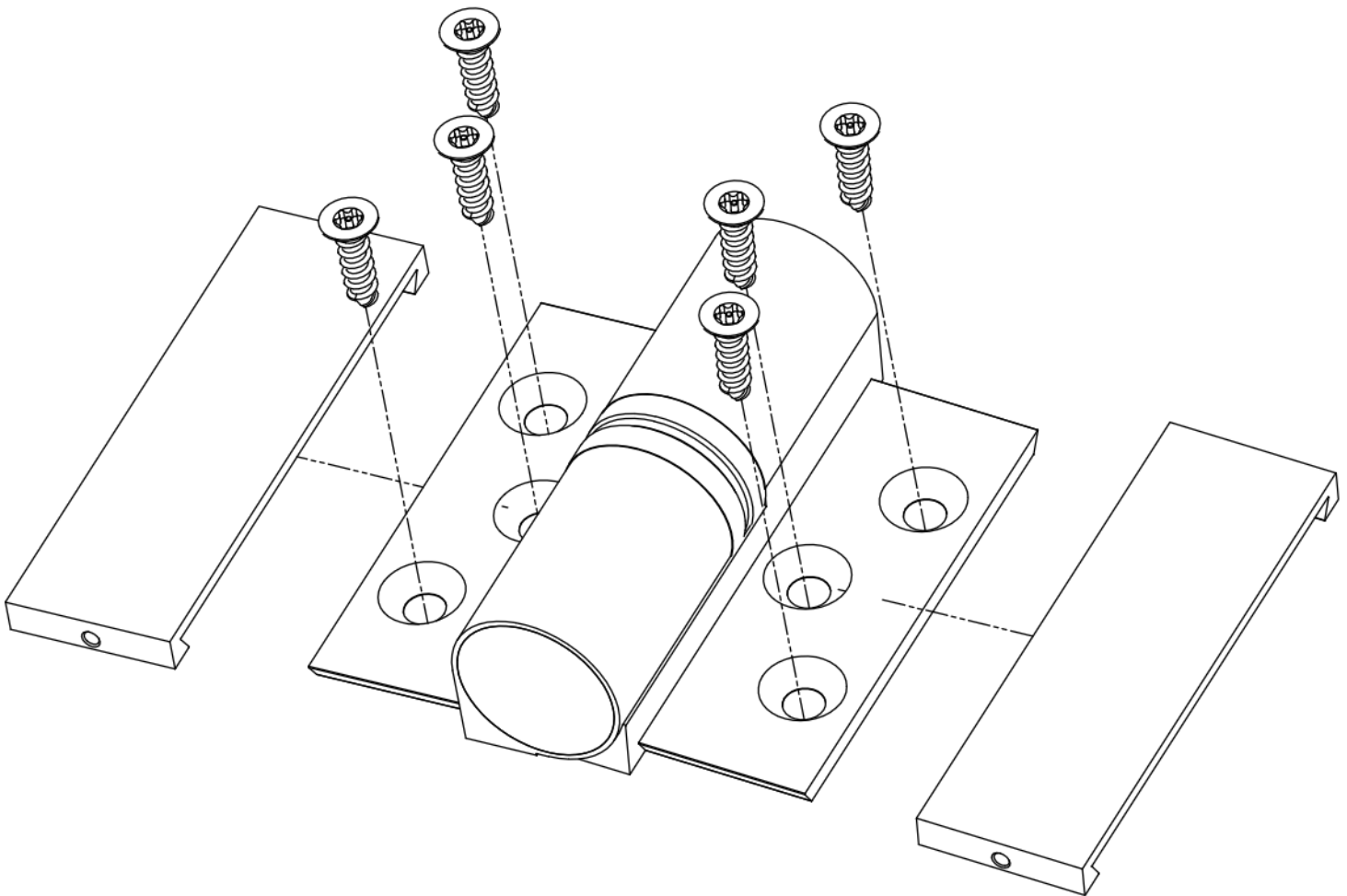

URINAL SCREEN INSTALLATION

- A. Before proceeding, confirm that the backing of the wall is adequate to support the mounting of urinal screens. Check shop drawings for layout.
- B. Mark wall bracket holes using the brackets as templates. the bottom of the bracket should sit at 1", above the bottom of the screen.
- C. Drill 1/4" diameter x 2 1/2" minimum deep holes for the red plastic shields provided using a 1/4" drill bit. However, as site conditions vary, an assortment of bit sizes is recommended.
- D. Insert the anchoring devices into the walls, and secure the wall brackets with #12 X 2 1/2 screws.
- E. Place urinal screen on a support device at desired height.
- F. Set the pilaster in the wall bracket. (And on pedestal if required)
- G. Level the pilaster and adjust the gap between the pilaster and wall.
- H. Using a 1/4" drill bit. Drill through the holes in the bracket.
- I. Fasten the pilaster to the wall bracket using 1/2" bolts & 3/8" nuts.

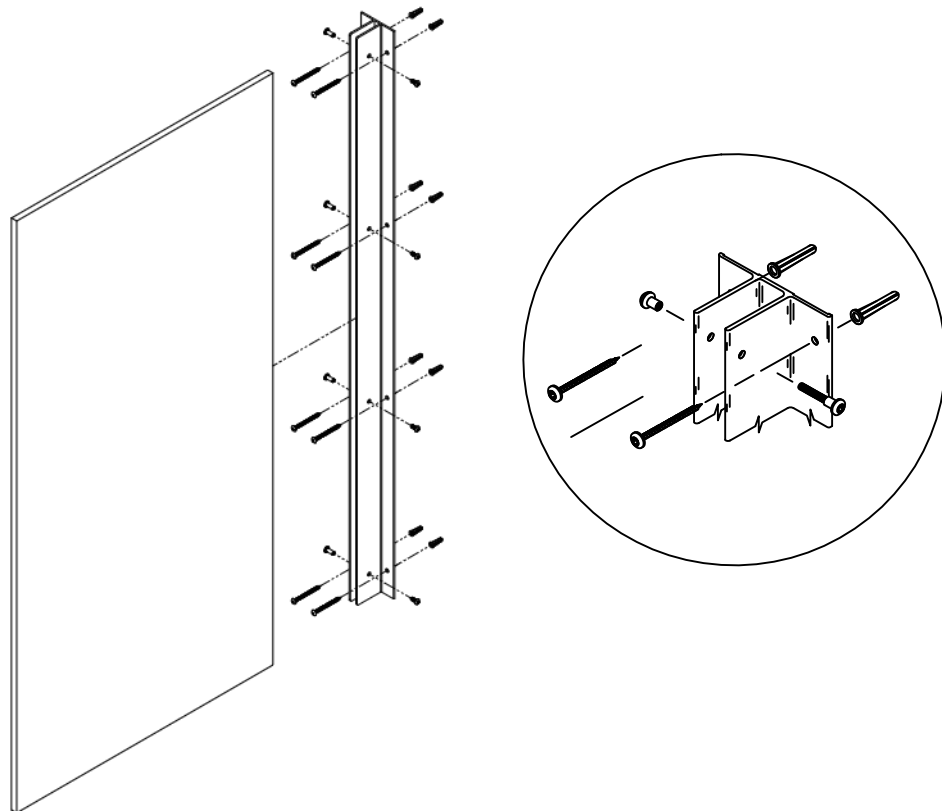

www.asi-globalpartitions.com

(706) 827-2700

ASI Global
Partitions

www.asi-accuratepartitions.com

(708) 442-6800

ASI Accurate
Partitions

CARE AND MAINTENANCE OF **BATHROOM PARTITIONS**

In order to provide bathroom partitions with proper care and maintenance, the following instructions must be followed

- A. All surfaces must be kept clean with water and a mild soap solution only.
- B. In areas of high humidity, the rooms must be properly ventilated.
- C. “Hosing down” or wet-washing of these units may cause water adsorption and damage.
- D. For maximum protection, periodic application of any standard furniture wax will be beneficial.

WARNING

Under no circumstances should these components be subjected to:

- Abrasive powders or pads
- Bathroom cleaners
- Ceramic tile cleaners
- Solutions containing more than 1% by volume of ammonia
- Solutions containing acids or lye
- Solutions containing enzymes

Attention to work progress during new construction or renovation is paramount.

Some cleaning services may use agents for ceramics and tiles that will damage these components.