

**Partition
Stalls**

Installation Manual

info@partitionstalls.com
646-453-4564

Table of Contents

• Stop before you begin	Page 1
• Suggested Tools	Page 1
• Partition Stalls Tips	Page 2
• Hardware nomenclature	Page 2
• Step 1 - Layout	Page 3
• Step 2 - Prepare Stiles	Page 3
• Step 3 - Position Panel	Page 3
• Step 4 - Attach Stiles	Page 4 - 6
• Step 5 - Secure Stiles to Panel	Page 7
• Step 6 - Headrail & Panel Fasten	Page 7
• Step 7 - Install Door	Page 7
• Step 8 - Care Maintenance	Page 8
• Step 9 - Need Help?	Page 8

Before you begin, note the following...

- Caution, safety first! Be certain to have and use the proper safety gear.
- Structural support in the walls, floors and/or ceiling is not supplied by Partition Stalls. Verify that adequate blocking has been installed where necessary before you proceed.
- This installation manual should be used in conjunction with the layout drawings prepared by Partition Stalls. Refer to the layout drawings for further information such as: product style (ie: The Corinthian FP-500 Overhead Braced), stall width and depth, ceiling height (for ceiling hung or floor-to-ceiling), individual component sizes (ie: panels, stiles &/or doors), etc. You will need the layout drawings to determine the centerline markings for drilling locations. If you have "no peek" design, you MUST have the layout drawing which includes special notes to indicate the location for each individual pilaster and door.
- When the material is shipped to you, an Initial Release (packing list) is included. Be certain that all items you need have been ordered and shipped properly.

Suggested Tools...

For your convenience, we recommend that you have the following tools:

Tape Measure, chalk line, pencil asking tape (to help you layout drilling locations), electric or battery operated drill, drill bits including torx pin head t27 bit, screwdriver (flathead and phillips head), center punch, plumb-bomb, level, hacksaw, hammer, shims, support blocks (12"high).

Partition Stalls tips...

1. IMPORTANT... For stainless steel partitions with stainless steel sheet metal screws, it is strongly suggested that you pre-drill pilot holes. For #10 screws use a #28 drill for a .140" hole. For #14 screws use a #10 drill for a .193" hole.
2. Plan ahead... coordinate all of the materials and hardware for each specific layout. Study your layout drawings and evaluate any special conditions that may require custom size materials, unique hardware or special tools.
3. When you determine the centerline dimensions, refer to the stall depths shown on your layout drawings. For Powder Shield, Stainless Steel and Plastic Laminate pilasters, the centerline is 5/8 " less than the stall depth. Solid Phenolic pilasters are 3/8"less.
4. Read all of these instructions carefully and thoroughly. Reading this manual first will better prepare you for the entire installation.

Hardware Nomenclature...

What does "p1" mean? What are all those little circles on my layout drawing? These indicate the hardware to be used at that location. Each one is an abbreviation for the bracket type. Each hardware package is marked with the same notation for easier identification.

- • P1 = One ear panel bracket
- P2 = Two ear panel bracket
- P3 = One ear alcove panel and post
- PF = "PF" Screen with panel and post
- WH = Wall hung urinal screen
- S1L = Stile one-ear long bracket (3" & up)
- S3L = Same as S1L but with 3 brackets
- S1LP = Stile one-ear bracket against panel
- S3M = Post one-ear mini bracket (3 per)
- EHR = End headrail brackets
- DB1 = Door bumper
- H -1 = Inswing door hardware
- H - 2 = Outswing door hardware
- H - 3 = Entry door hardware
- P-S-1 = Inswing Post to Stile Door Hardware (post on hinge side of door & stile on strike side)
- P-S-2 = Outswing Post to Stile Door Hardware (post on hinge side of door & stile on strike side)

STEP 1 - LAYOUT

- Mark the centerline for the pilasters from the back wall. The centerline of the stile is $5/8"$ less than overall dimension shown. Phenolic = $3/8"$ less. Measure out at each end of overall distance from first stall to last in line.
- Mark the centerline for all top and bottom wall brackets. Adjust if possible to locate in mortar joints. CAUTION: if doors use S/S surface hinges, you may need to raise or lower the wall brackets on 2", 3" and 4" stiles to avoid any conflict with the door hinges.
- From side wall, measure along the centerline of the pilasters to locate the floor fasteners, to be located 1" in from each end of each pilaster. FP stiles at 2" and 3" use only (1) floor mounting. FT and CH stiles at 2", 3", 4" and 5" use only (1) mounting.
- Mark bracket holes to be drilled using brackets as templates.
- Drill $1/4"$ holes for wall brackets.
- Drill holes for floor fasteners, $1/4"$ for FP500, $3/8"$ for FT700.
- Secure wall brackets with #12 X $2 1/2"$ screws. Pilaster brackets have wider space between the legs because a stile is thicker than panel.

STEP 2 - PREPARE STILES

- Note: For S/S partitions using S/S metal screws, pre-drill pilot holes. For #10 screws use #28 drill for a .140" hole. For #14 screws use #10 for a .193" hole. Do this now and all future steps for panels, doors and pilasters.
- Locate the U-brackets against the pilaster using the centerline dimensions. For Plastic and Phenolic, a 1-ear or 2-ear bracket will be used behind the pilaster. For FP500 and FT700 measure downward* from the top. For CH-700, measure upward from the bottom of the stiles. Fasten the brackets in place with sheet metal screws.
- One FP500 stiles, drill 2 pilot holes through the top back of the stiles for headrail screws.
- Extend the leveling bolt (jack studs) from the top of FP500 stiles to the bottom of the leveling bolted to 82"
- Slide the stainless steel plinth onto the stile.

**NOTE: Measure downward 18" for Powder Shield or Stainless Steel. Measure 16 1/2" downward for Plastic Laminate or Phenolic.

STEP 3 - POSITION PANEL

- Set the panel onto some type of support 12" high in position to hold the panel.
- Set the panel into the wall bracket but do not fasten the panel to the brackets yet.

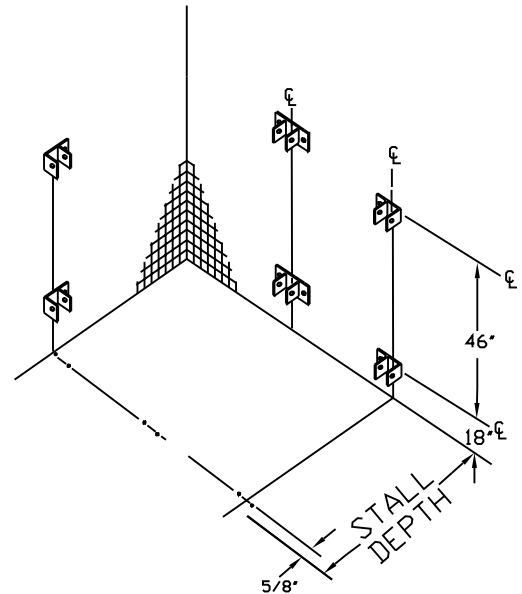

1-A

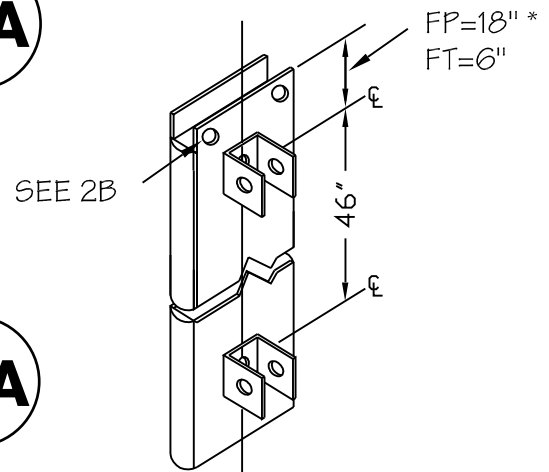

2-A

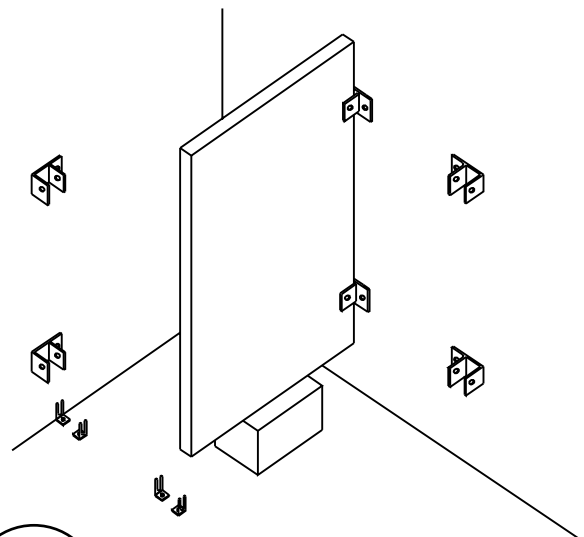

3-A

STEP 4A - ATTACH STILE FP500

- Place plastic anchors into the floor holes.
- Over each floor anchor place these items in the following order; one (1) shoe clip and one (1) bracket. Fasten into anchor with #12 x 2 1/2" screw.
- Place stile over L-brackets and push panel into U-brackets up to screw heads. Fasten one #14 x 5/8" screw through each L-bracket.
- Plumb stile, place wedge at top rear between panel and wall.
- Fasten U-brackets to panel. Remove panel support.

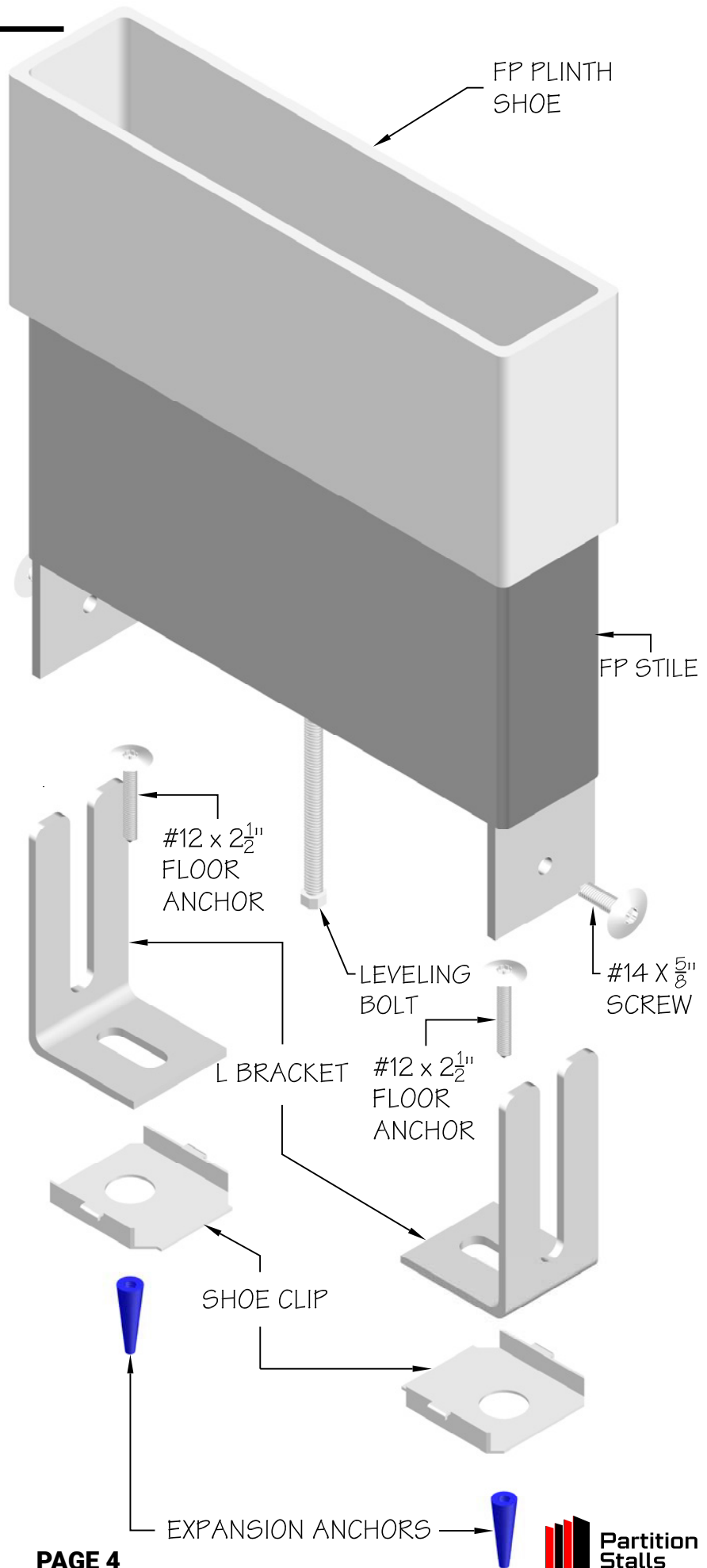

FP L BRACKET ASSEMBLED

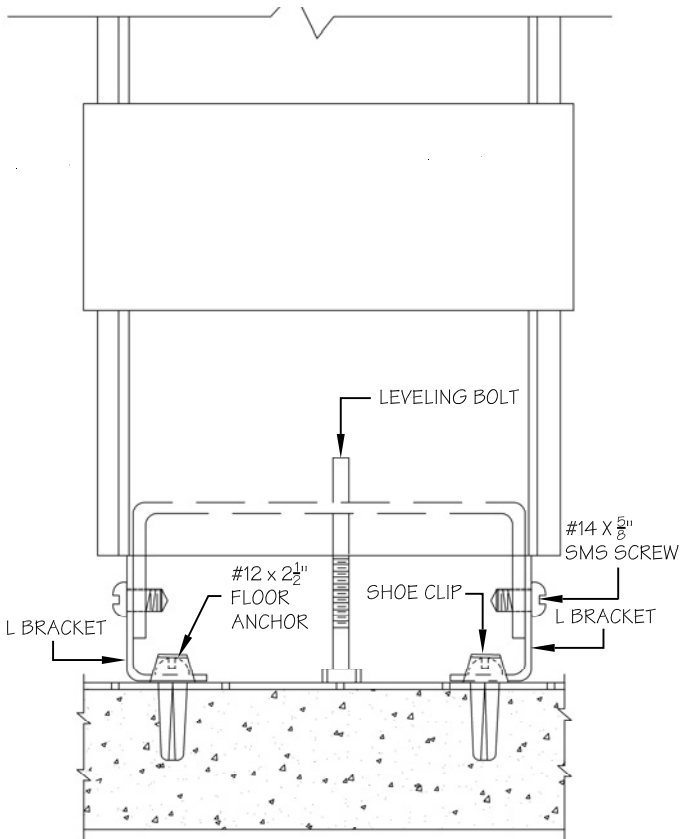

STEP 4B - CH700 PILASTER ATTACHMENT

- On each 3/8" diameter ceiling stud, place these items in the following order: one (1) shoe clip. One (1) rectangular washer, two (2) hex nuts and one (1) washer.
- Place stile over studs and place on each stud one (1) clamp, one (1) round washer and one (1) hex nut.
- Bottom of panel and bottom of stile should align and be even.
- Plumb stile, place wedge at top rear between panel and wall.
- Fasten U-brackets to panel. Remove panel support.

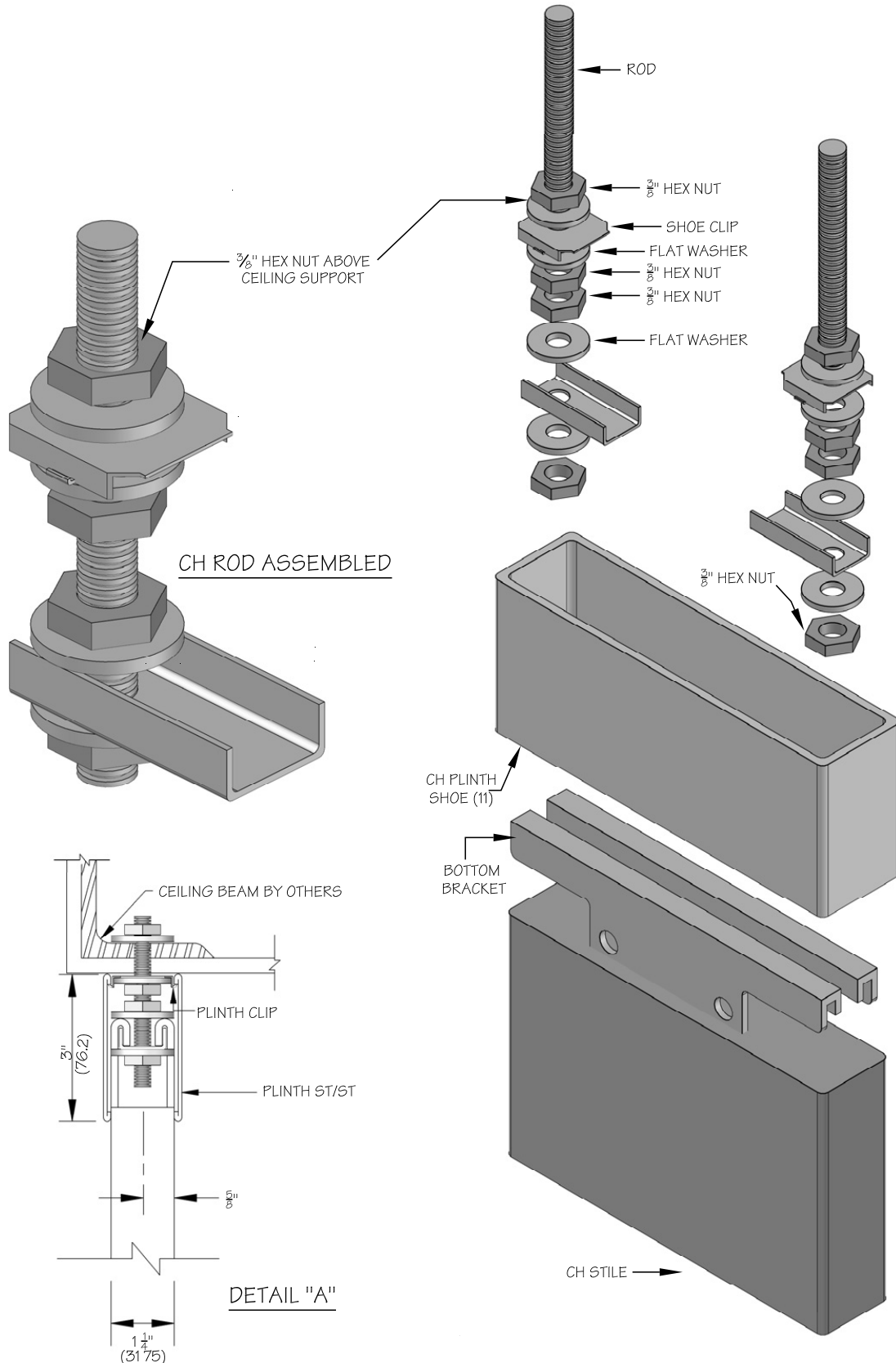

STEP 4C - FT-700 PILASTER ATTACHMENT

- A. Place expansion shield (1) into floor boards.
- B. Screw 3/8" rods (2) into expansion shields (1).
- C. Place a shoe clips (3), flat washer (4) and hex nut (5) onto the rod (2) and tighten to expand shield.
- D. Place one hex nut (6) and then one flat washer (7) onto each rod (2). Lower it near the bottom. These will be raised later and tightened underneath the stile bottom bracket (12).
- E. Slide the plinth (11) onto the stile (13) and move upwards out of the way for now.
- F. Position and lower the stile (13) onto the rods (2).
- G. Place the FT Clamps (8) over the 2 legs of the bottom bracket (12) of the stile.
- H. Place the one flat washer (9) and hex nut (10) onto each rod (2) and tighten over the FT Clamp (8).
- I. Top of the stile and panel should align. Position panel into brackets installed behind stiles.
- J. Plumb the stile and place a wedge between the top rear of the panel and the wall. Repeat between the panel and stile if necessary. DO NOT fasten the panel in place yet and DO NOT remove the panel support blocks at the floor.
- K. Adjustments can be made to stile (13) to correct height, plumb level by raising/lowering the hex nuts (6 & 10) above/below the FT Clamp.

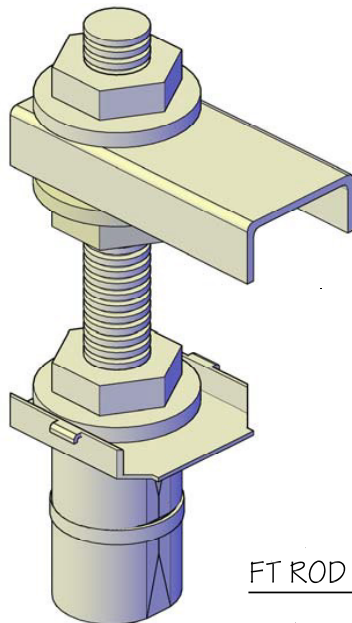

FT ROD ASSEMBLED

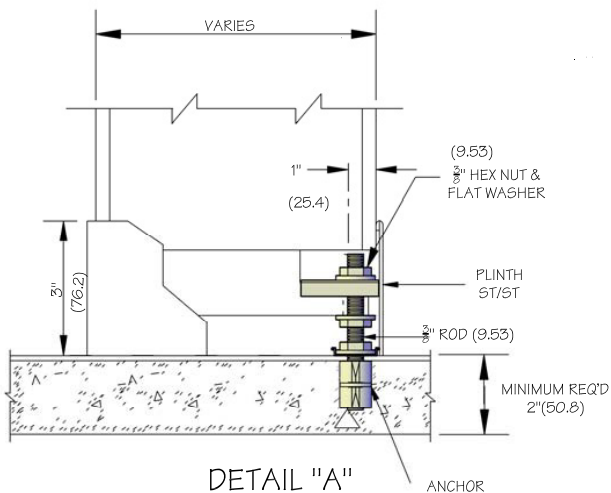
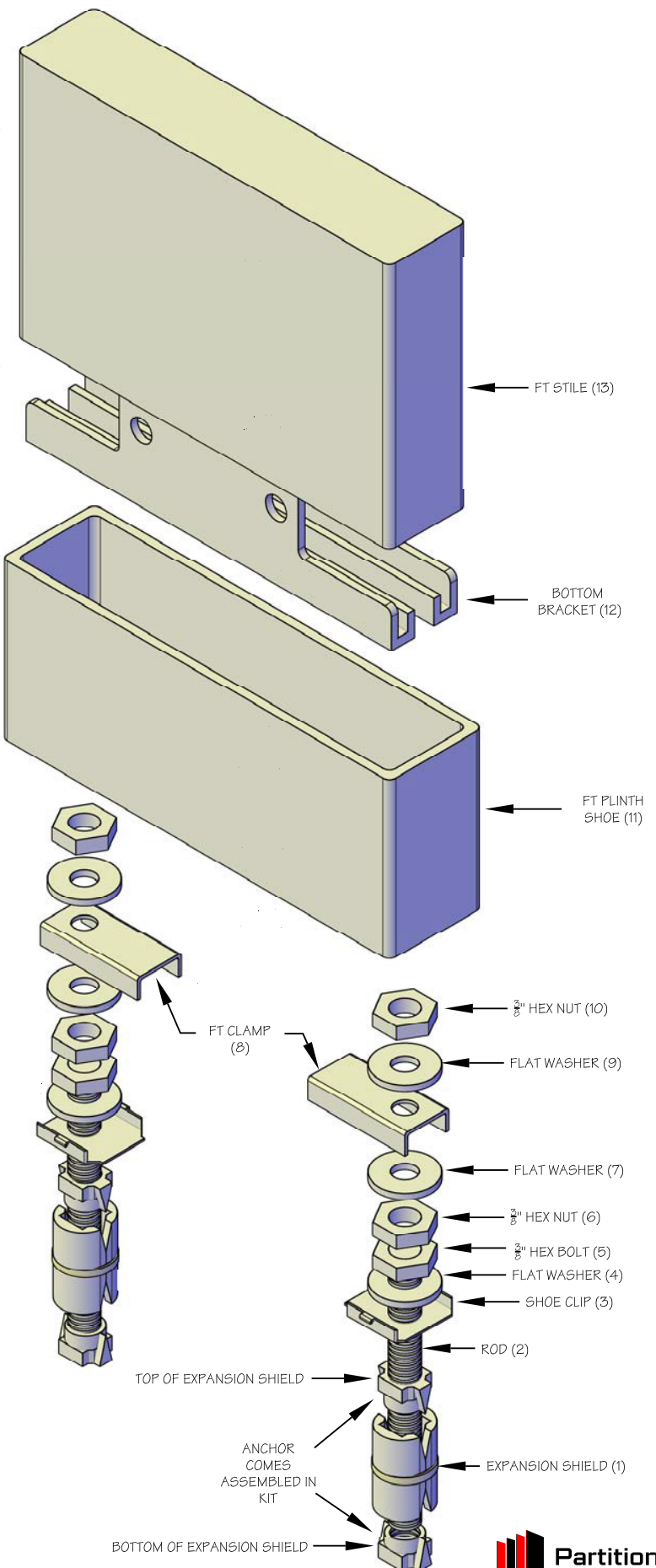

DETAIL "A"

STEP 5 - SECURING STILES TO PANELS

- Stiles must be both plumb and level. Headrail may be used as an aide in this process by temporarily setting them in position. (DO NOT fasten at this time).
- Plumb stile and adjust elevation. Fasten stile to panel using sheet metal screws.
- By adjusting stile L-brackets on FP500. The proper door opening and stile elevation can be attained and set in position by tightening screws.

STEP 6 - HEADRAIL AND PANEL FASTENING

- Place headrail into top of stiles. Plumb while setting door gaps, and fasten headrail to stiles using two (2) #14 x 5/8" sheet metal screws.
- Fasten panel to wall brackets using #14 x 5/8" sheet metal screws.
- Slide stainless steel plinth down to floor level firmly engaging shoe clips.
- Cut excess headrail 1/8" to 1/4" past end of stile. Insert headrail end plug.
- To ensure rigidity, install rectangular end-headrail to depth of last stall by securing with U-brackets at back of stile and also with a 2-ear headrail bracket at the back wall. Align over the end panel.

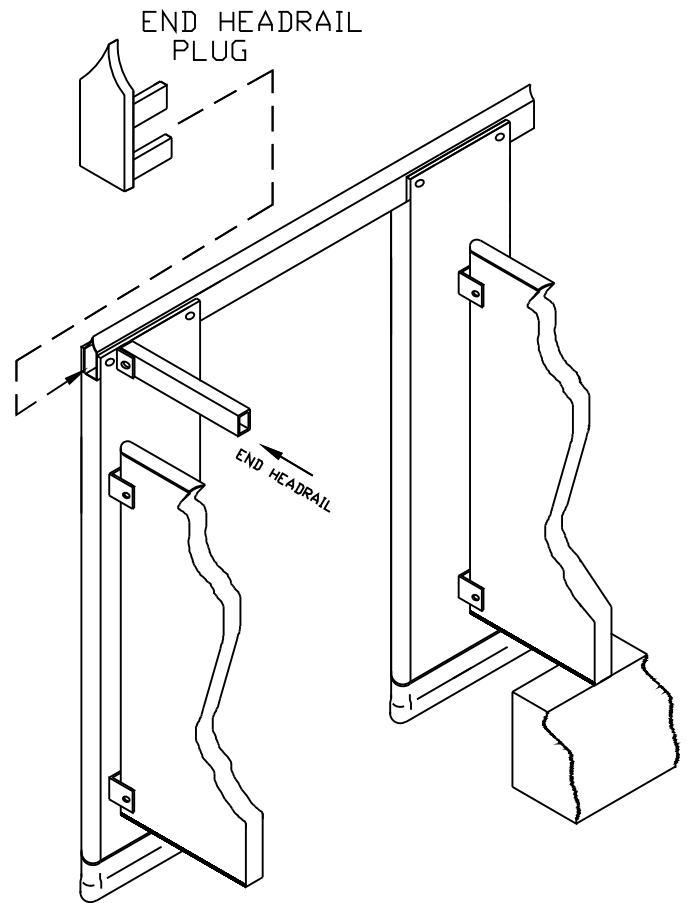

STEP 7 - INSTALL DOOR

- Secure top and bottom hinge brackets onto stile with thru-bolts and barrel nuts through pre-drilled clearance holes.
- Assemble slide latch on door through pre-punched hole. Additional instructions and details are provided with the slide latch hardware package. Install coat hook/bumper.
- Install stay set cam on lower hinge bracket being sure to place the long tab on the square part of the stay set cam towards the inside of the door and the short tab to the stile. Set the rest position of the door and tighten.
- Install door onto hinge bracket with pintle and stay set cam as shown.
- Install strike/keeper onto stile. Align with door latch, fasten with thru-bolts and barrel nuts.

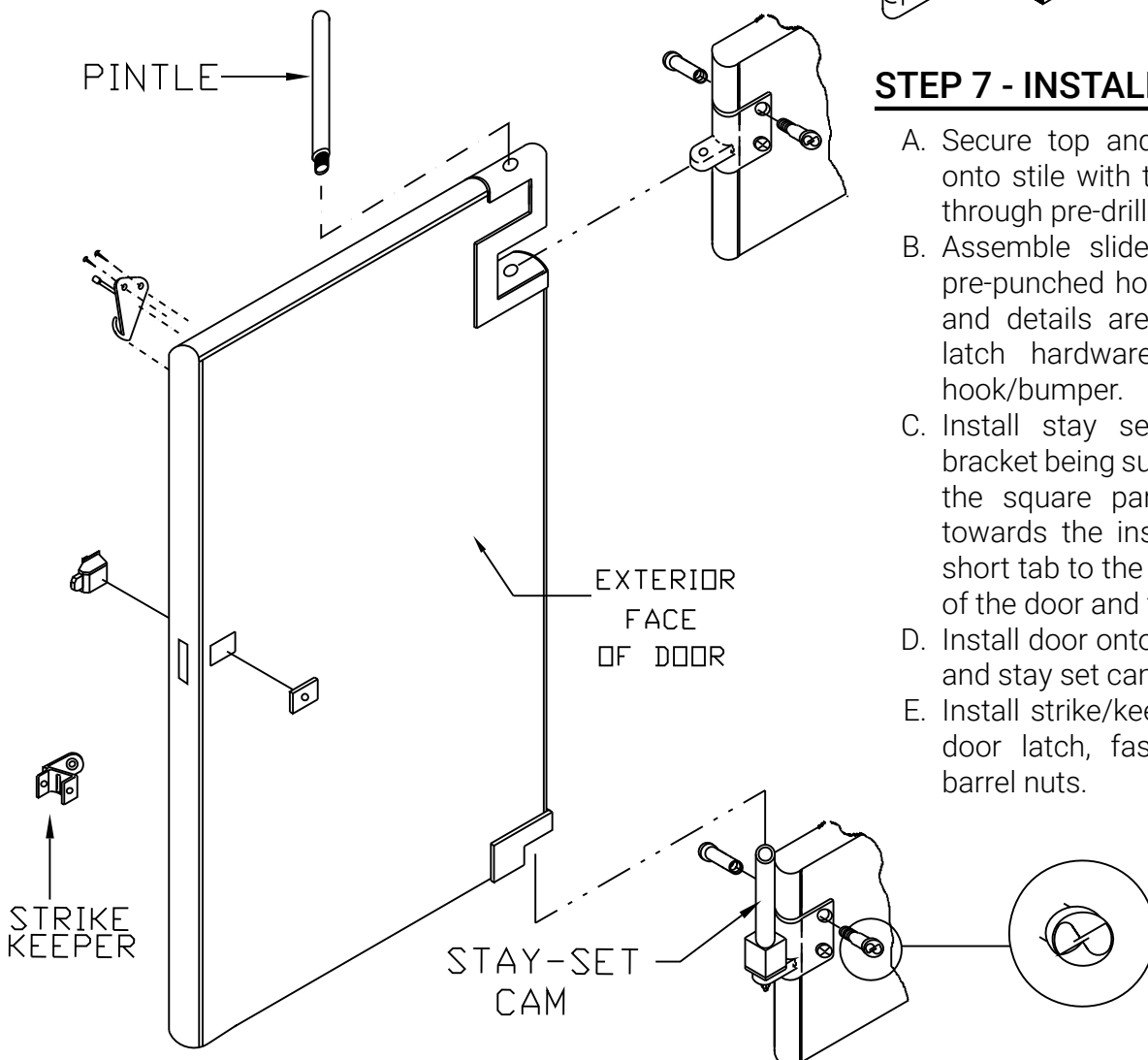

CARE AND MAINTENANCE OF TOILET PARTITIONS

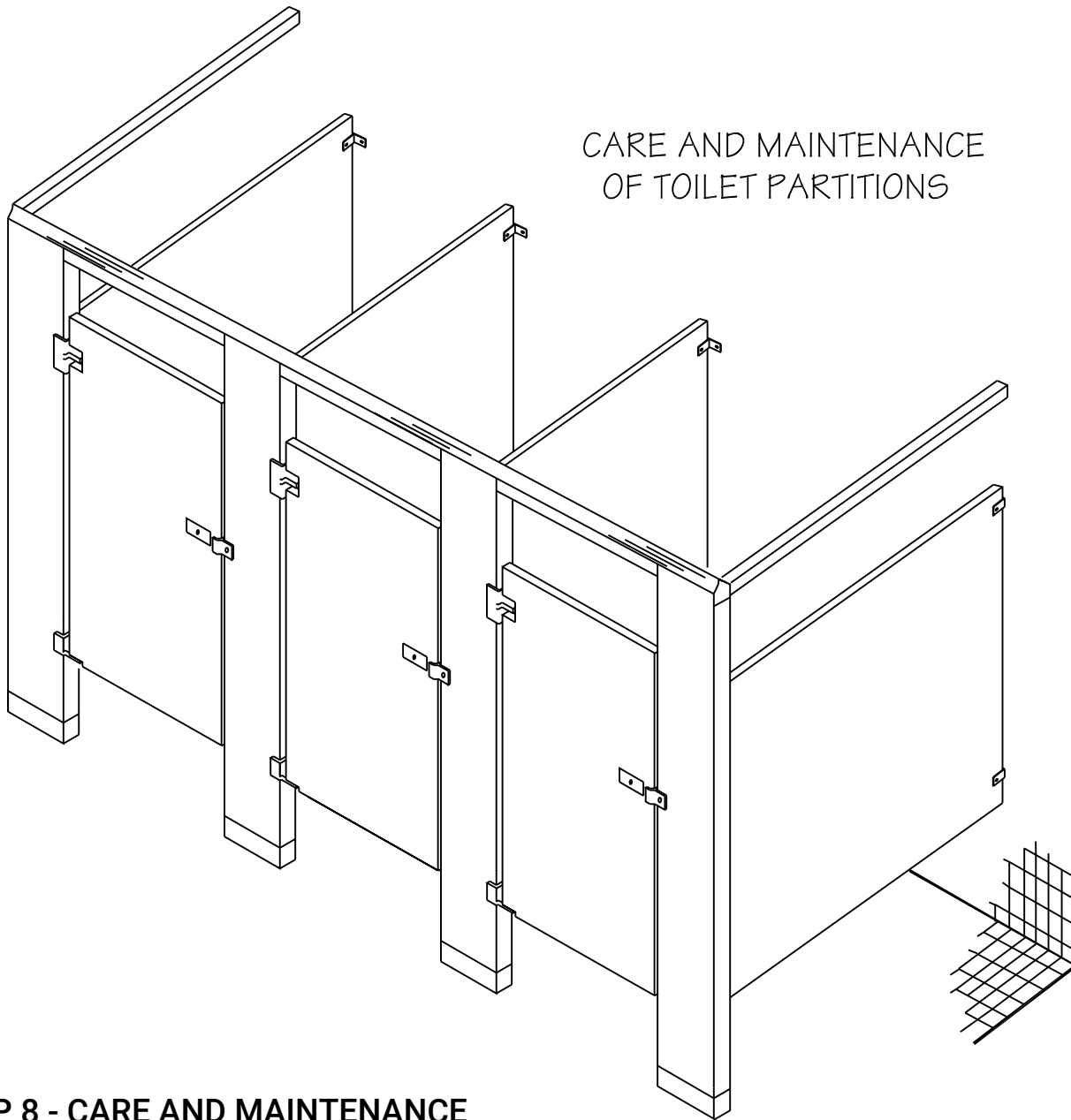

STEP 8 - CARE AND MAINTENANCE

- A. All surfaces must be kept clean with water and mild soap solution.
- B. Water left on units for extended periods of time will damage surface. The finish must be wiped dry following cleaning.
- C. In high humidity areas, the rooms must be properly ventilated.
- D. For maximum protection, periodic applications of good quality car wax will be beneficial for powder shield materials.

STEP 9 - NEED HELP?

- A. In the unlikely event that you need further help, you have several resources. First, contact the Partition Stalls representative from which you purchased the materials. They are best equipped to assist you since they are already familiar with your project and experienced with Partition Stalls products.
- B. Another quick and easy source of information is the Partition Stalls web site. Here you'll find a cornucopia of information, details specifications and technical support and so much more. Our URL address is <http://www.PartitionStalls.com> or send e-mail to info@partitionstalls.com
- C. You can also contact us by phone at 646-453-4564.