



**Partition
Stalls**

POLLY Installation Manual



info@partitionstalls.com
646-453-4564

Table of Contents

• Stop! Before you begin	Page 1
• Suggested tools	Page 1
• Partition Stalls tips	Page 2
• Hardware nomenclature	Page 2
• Step 1 - Layout	Page 3
• Step 2 - Prepare Stiles	Page 3
• Step 3 - Position Panel	Page 3
• Step 4 - Attach Stiles	Page 4
• Step 5 - Secure stiles to panel	Page 5
• Step 6 - Headrail & Panel fasten	Page 5
• Step 7 - Door & Hinges	Page 6
• Step 7 – Wraparound Hinges	Page 7
• Step 8 – Install Door Latch	Page 8
• Step 9 – Care & Maintenance	Page 8
• Step 10 - Need Help?	Page 8



Before you begin, note the following...

- Caution, safety first! Be certain to have and use the proper safety gear.
- Structural support in the walls, floors and/or ceiling is not supplied by Partition Stalls. Verify that adequate blocking has been installed where necessary before you proceed.
- This installation manual should be used in conjunction with the layout drawings prepared by Partition Stalls. Refer to the layout drawings for further information such as: product style (ie: The Corinthian FP-500 Overhead Braced), stall width and depth, ceiling height (for ceiling hung or floor-to-ceiling), individual component sizes (ie: panels, stiles &/or doors), etc. You will need the layout drawings to determine the centerline markings for drilling locations. If you have “no peek” design, you MUST have the layout drawing which includes special notes to indicate the location for each individual pilaster and door.
- When the material is shipped to you, an Initial Release (packing list) is included. Be certain that all items you need have been ordered and shipped properly.



Suggested Tools...

For your convenience, we recommend that you have the following tools:
Tape Measure, chalk line, pencil asking tape (to help you layout drilling locations), electric or battery operated drill, drill bits including torx pin head t27 bit, screwdriver (flathead and phillips head), center punch, plumb-bomb, level, hacksaw, hammer, shims, support blocks (12”high).

Partition Stalls tips...

1. IMPORTANT... For stainless steel partitions with stainless steel sheet metal screws, it is strongly suggested that you pre-drill pilot holes. For #10 screws use a #28 drill for a .140" hole. For #14 screws use a #10 drill for a .193" hole.
2. Plan ahead... coordinate all of the materials and hardware for each specific layout. Study your layout drawings and evaluate any special conditions that may require custom size materials, unique hardware or special tools.
3. When you determine the centerline dimensions, refer to the stall depths shown on your layout drawings. For Powder Shield, Stainless Steel and Plastic Laminate pilasters, the centerline is 5/8 " less than the stall depth. Solid Phenolic pilasters are 3/8"less.
4. Read all of these instructions carefully and thoroughly. Reading this manual first will better prepare you for the entire installation.

Hardware Nomenclature...

What does "p1" mean? What are all those little circles on my layout drawing? These indicate the hardware to be used at that location. Each one is an abbreviation for the bracket type. Each hardware package is marked with the same notation for easier identification.

- • P1 = One ear panel bracket
- P2 = Two ear panel bracket
- P3 = One ear alcove panel and post
- PF = "PF" Screen with panel and post
- WH = Wall hung urinal screen
- S1L = Stile one-ear long bracket (3" & up)
- S3L = Same as S1L but with 3 brackets
- S1LP = Stile one-ear bracket against panel
- S3M = Post one-ear mini bracket (3 per)
- EHR = End headrail brackets
- DB1 = Door bumper
- H -1 = Inswing door hardware
- H - 2 = Outswing door hardware
- H - 3 = Entry door hardware
- P-S-1 = Inswing Post to Stile Door Hardware (post on hinge side of door & stile on strike side)
- P-S-2 = Outswing Post to Stile Door Hardware (post on hinge side of door & stile on strike side)

Partition Stalls tips...

1. Plan ahead... coordinate all of the materials and hardware for each specific layout. Study your layout drawings and evaluate any special conditions that may require custom size materials, unique hardware or special tools.
2. When you determine the centerline dimensions, refer to the stall depths shown on your layout drawings. The centerline is $\frac{1}{2}$ " less than the stall depth.
3. Read all of these instructions carefully and thoroughly. Reading this manual first will better prepare you for the entire installation.

? Hardware Nomenclature...

Polly orders are normally provided with 3" high stirrup or 54" full height bright dipped anodized aluminum brackets. (also available in stainless steel). Panels, doors and pilasters are all 1" thick. The brackets are inter-changeable and can be used on panels or pilasters. The Partition Stalls drawings will illustrate the type of bracket to be used at each location.

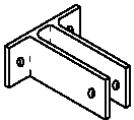

#144 2-ear bracket for panel-to-wall and panel-to-stile connections.

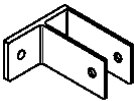

#145 1-ear bracket for panel-to-wall, panel-to-stile or stile-to-wall connections.

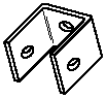

#148 or #142 U-Brackets. #148 shallow U-Bracket for panel-to-stile connection. Or #142 deep U-Bracket for any connection. Also used on panel-to-post connections such as on a "PF" screen.

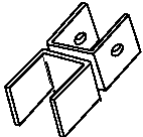

#142 and 148 H-bracket assembly (2 individual pieces of U-Brackets) used for alcove panels attached "in-line" with the edge of a pilaster.

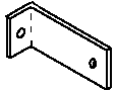

1 1/2" x 2" aluminum or 1" x 2 1/4" stainless steel angles for panel-to-wall or pilaster-to-wall.

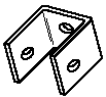

#148 Headrail U-bracket (CP Zamac #12410) used to attach the end of the headrail to the wall.

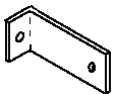

1 1/2" x 2" x 1 1/4" angle in the Headrail Angle Kit (Alum only #15921) attach headrail to perpendicular headrail or to the wall.

STEP 1 - LAYOUT

- Mark the centerline of each stile location from the back wall. The centerline of the stile is $\frac{1}{2}$ " less than the overall dimension shown. Measure out at each end of overall distance from first stall to last line.
- Mark the centerline of all wall brackets. Full length 1-ear & 2-ear shown. U-Brackets and stirrup brackets also available.
- From the sidewall measure along the centerline of the stiles to locate the floor fasteners, to be located 1" in from each end of each pilaster.
- Mark all bracket holes to be drilled using brackets as templates.
- Drill $\frac{1}{4}$ " holes for wall brackets and floor fastenings.
- Insert plastic anchors into holes (See detail 4A).
- Secure wall brackets with #12 x $2\frac{1}{2}$ " screws.

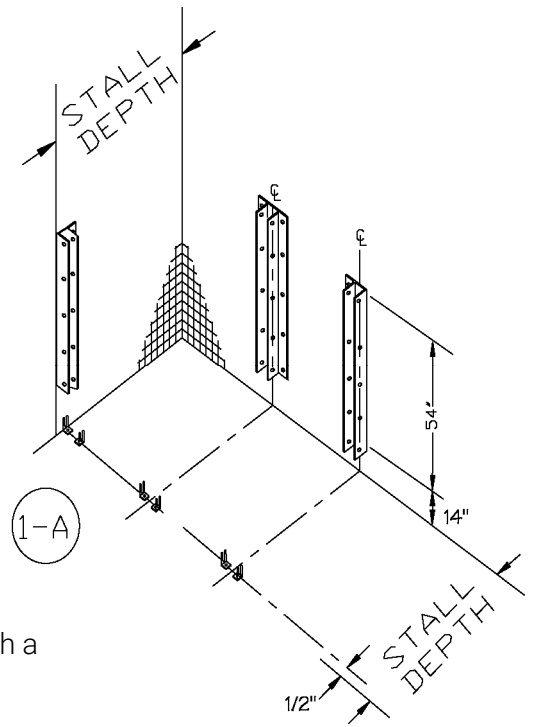

STEP 2 - PREPARE STILES

- If you have the "No Peek" design, then each pilaster is prepared with a special rabbet on either side for the door strike or door hinge. This rabbet will change for inswing or outswing. It is very important to review your Partition Stalls layout drawings to determine which pilaster is used at each specific location by matching the note illustrated next to each pilaster (ie; PYS4).
- Locate the "1-ear", "2-ear" or "U" brackets against the back of each pilaster using the centerline dimensions. For FP500, measure down $12\frac{1}{2}$ " from the top (see detail 2A). For FT700, measure down $\frac{1}{2}$ " from top. For CH700 measure up $\frac{1}{2}$ " from bottom. NOTE: CH700 pilasters use 70" pilaster brackets. Fasten the bracket in place with #14 x $\frac{3}{4}$ " sheet metal screws.
- For FP500 stiles, extend the leveling bolt (jackstuds) so that it measures $80\frac{1}{2}$ " from the top of stiles to the bottom of the leveling bolt head.
- Slide the stainless steel plinth onto the stile, but do not fasten. Hold in place temporarily.
- DO NOT install the pilasters in position until after step 3.

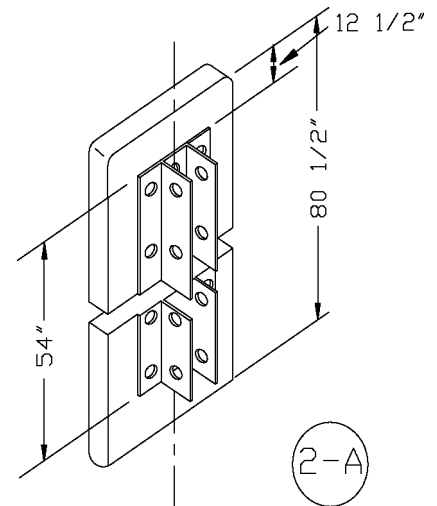

STEP 3 - POSITION PANEL

- Set the panel onto some type of support ($13\frac{1}{2}$ " high for FP500 and CH700, or 15" high for FT700) to maintain its elevation. See detail 3A.
- Orientate the panel so the metal heat sink is on the bottom. See detail below.
- Set the panel into the wall brackets BUT, DO NOT fasten the panel to the wall brackets yet.

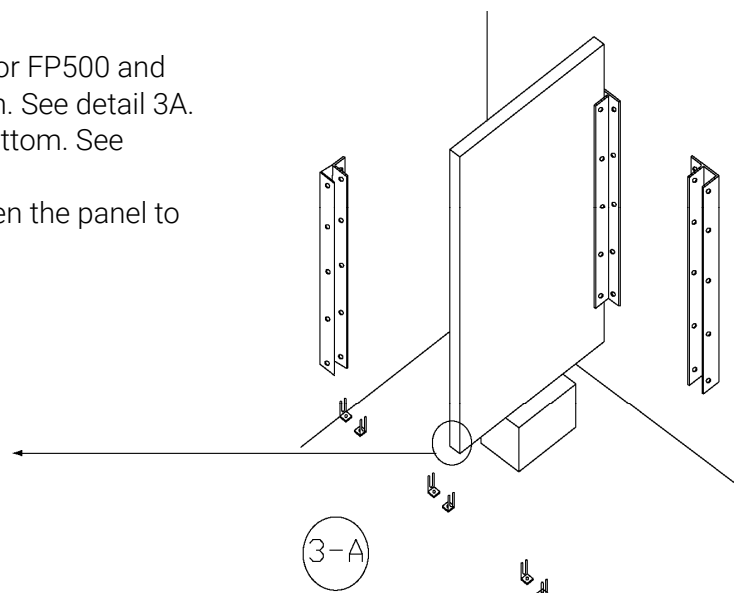
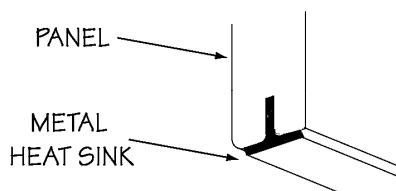

STEP 4A - ATTACH STILE FP500 w/ Stainless Steel Plinth

- Place plastic anchors into the floor holes.
- Over each floor anchor place these items in the following order; one (1) shoe clip and one (1) bracket. Fasten into anchor with #12 x 1½" screw
- Loosely install ¼-20 nuts and bolts thru each bracket on bottom of stiles. Note the use of washers on either side of each L-bracket. See detail 4-C.
- Place stile over L-brackets and push panel into the brackets previously installed onto the back of each stile. Push up to the screw heads.
- Plumb the stile, place a wedge at top rear between panel and wall. Leave panel support at floor.

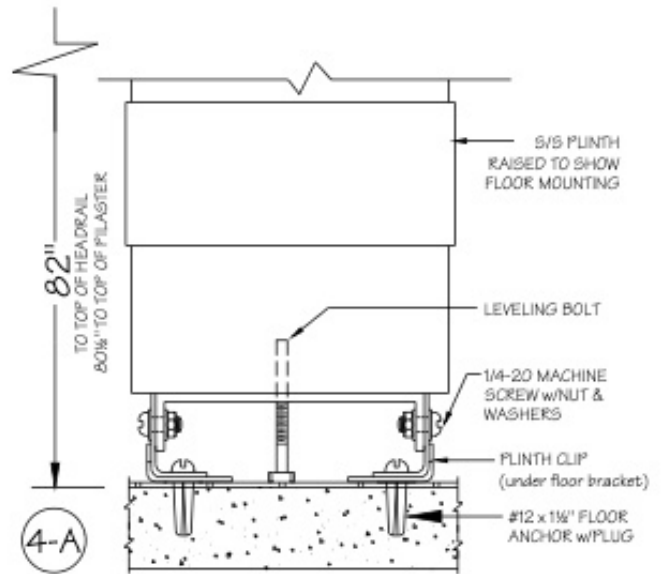

STEP 4B - ATTACH STILE CH700

- On each 3/8" diameter ceiling stud, place these items in the following order; one (1) shoe clip, one (1) rectangular washer, two (2) nuts and one (1) washer.
- Place stile over studs and place on each stud one (1) clamp, one (1) round washer and one (1) nut.
- Bottom of panel and bottom of stile should align and be even. Push panel into "1-ear" or "2-ear" 70" long brackets (previously installed onto the back of each stile) and push up to screw heads.
- Plumb stile, place wedge at top rear between panel and wall. Leave the panel support at floor beneath panel.
- Insert and fasten in place a 2½" x 16" "filler piece" into the cavity of the bracket above the panel (see detail).
- Locate the Polly Support Rail along the length of the stalls, behind the pilasters as shown, just above the bracket. This should extend to the side wall(s). Fasten to the back of the pilasters with sheet metal screws and mount to the wall with angle bracket as shown.

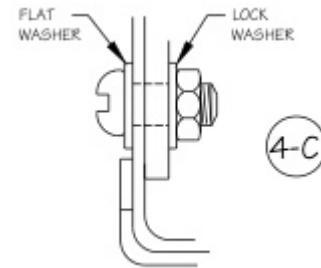

- The Polly Support Rail is used as shown solely on the CH700 ceiling hung style to provide reinforcement and stability. The extended 70" full height bracket with a "Polly filler" is also unique to CH700.

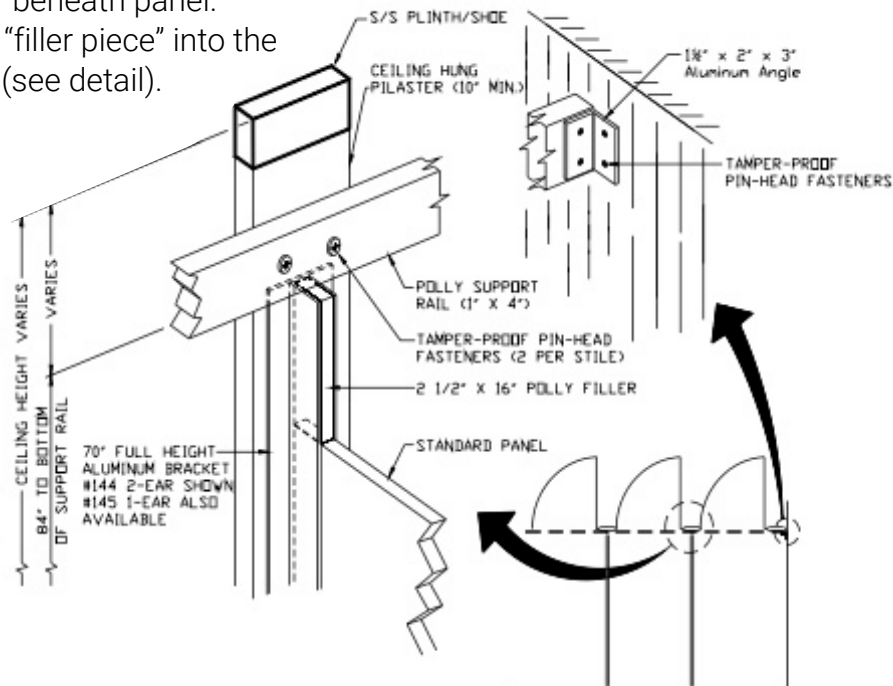

STEP 4C - ATTACH STILE FT700

- A. Place expansion shields into floor holes.
- B. Screw (hand tight) 3/8" studs into shields.
- C. On each stud place these items in the following order; one (1) shoe clip and one (1) washer.
- D. Screw one (1) 3/8" nut onto each stud. Tighten nuts to expand anchor. Place one (1) nut and one (1) round washer onto each stud.
- E. Lower the stile over the studs and place on each stud these items in the following order; one (1) clamp, one (1) round washer, screw on one (1) nut.
- F. Top of stile and top of panel should align and be even. Push panel into "1-ear" or "2-ear" brackets (previously installed onto the back of each stile) and push up to screw heads.
- G. Plumb stile, place wedge at top rear between panel and wall. Do not remove panel support at floor.

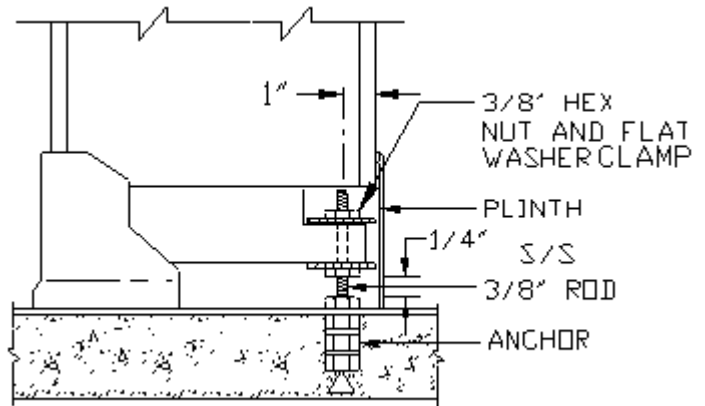

STEP 5 - SECURING STILES TO PANELS

- A. Stiles must be both plumb and level. Headrail may be used as an aid in this process by temporarily setting them in position (DO NOT fasten it at this time).
- B. Plumb stile and adjust elevation. Fasten stile to panel using #14 x 5/8" sheet metal screws on both sides of panel through bracket.
- C. By adjusting L-brackets on the bottom of the FP500 stiles, the proper door opening and stile elevation can be attained and set in position by tightening screws.

STEP 6 - HEADRAIL & PANEL FASTENING

- A. Place headrail onto top of stiles. Starting at one wall (preferably at hinge side) set gap between stile and wall, plumb stile and anchor stile to bracket at wall. Headrail will extend beyond stile to wall. Fasten headrail to pilaster and then to wall with headrail bracket.
- B. Install one door (STEP 7). If you have the "no-peek" design, then each door is prepared with a special rabbet on both sides for the door hinge or door strike. The rabbet will change for inswing or outswing. It is very important to review your Partition Stalls layout drawings to determine which door is used at each location by matching the note (ie; PYD2). Set door gap and plumb next stile and anchor headrail to top of that stile. Proceed, ONE PILASTER AND DOOR AT A TIME, setting gaps, plumbing, and anchoring headrail. Fasten headrail to stiles.
- C. Fasten panel to wall brackets using #14 x 5/8" screws.
- D. Tighten 1/4-20 nuts and bolts at bottom of each stile. Slide stainless steel plinth down to floor level firmly.
- E. At the last corner pilaster (if not at a wall) cut excess headrail even with radius of stile. Insert headrail end plug.
- F. To insure rigidity, install rectangular end-headrail to depth of last stall by securing with U-bracket at back of stile and also with a 2-ear headrail bracket at the back wall. Align over the end panel.

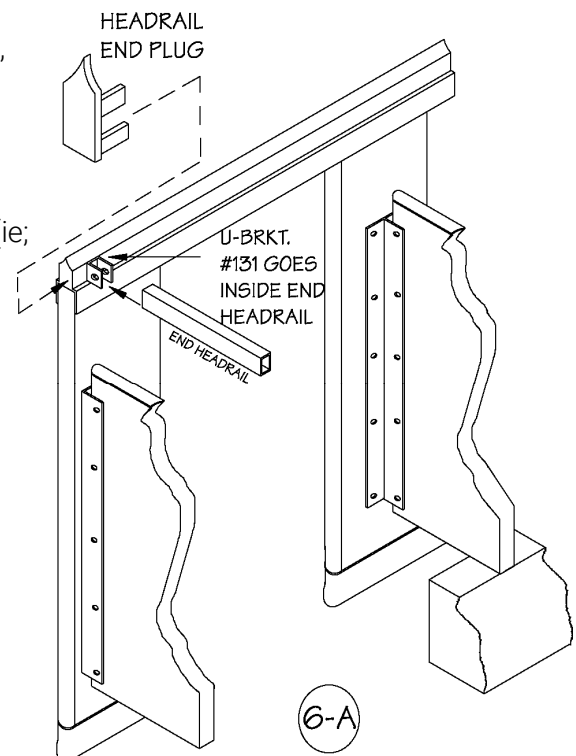

STEP 7A - DOOR INSTALLATION WITH INTEGRAL HINGE

- Review this detail and read the instructions before you begin. Be certain that you have all the correct parts.
- Turn the door over so the bottom is "face up". The bottom has a metal heat sink. Insert the female half of the 2-piece cam into the bottom hole of the door. With a 1/8" drill bit, drill a 1/8" hole through the edge of the door into the nylon cam. Screw the setscrew to lock the cam in place.

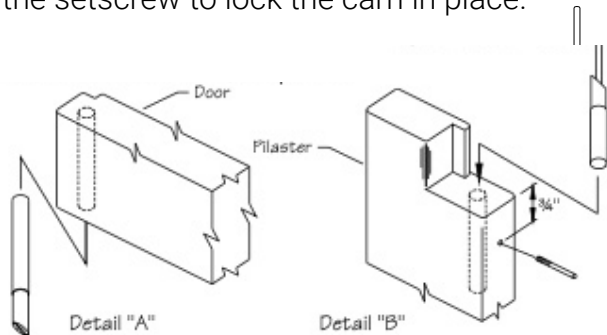

- Insert the male half of the 2-piece cam into the hole at the bottom of the pilaster. DO NOT drill the setscrew yet.
- Turn the door right side up. Insert the coil spring into the hole at the top of the door with the nylon top pin on top of the spring.
- Position the door on the pilaster. Mate the lower 2-piece cams together. Press down on the top pin and align it with the upper hole of the pilaster. Release the top pin so that it springs up into the hole thus securing the door position.
- Position the door at the desired degree (rest position). Drill through the side of the pilaster 3/4" above and below the door (see detail "B" above) for the setscrew.

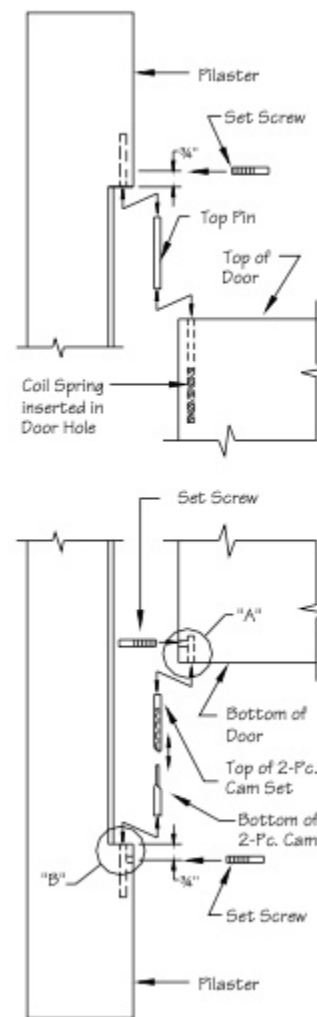

STEP 7B - DOOR INSTALLATION W/ MULTI-CAMS HINGE

- Lay the hinge on the pilaster as shown. Use it as a template to locate the correct position of the holes. For Multi-Cam hinges on a post, see separate detail.
- Drill a 1/4" diameter clearance hole using the top hole only of the hinge as a guide. Drill completely through the pilaster.
- Repeat previous step for the bottom hole in the hinge. Then remove the hinge.
- With the 2 clearance holes on top and bottom now drilled, install the hinge in its correct position. Fasten the hinge onto the pilaster with thru-bolts through the top and bottom holes.
- Use a 5/32" drill bit to drill a blind hole through the 4 holes remaining in the hinge leaf. Fasten with #14 x 5/8" sheet metal screws onto the pilaster. DO NOT drill through the pilaster.
- Repeat steps 7B.A through 7B.E to install the hinge onto the door.

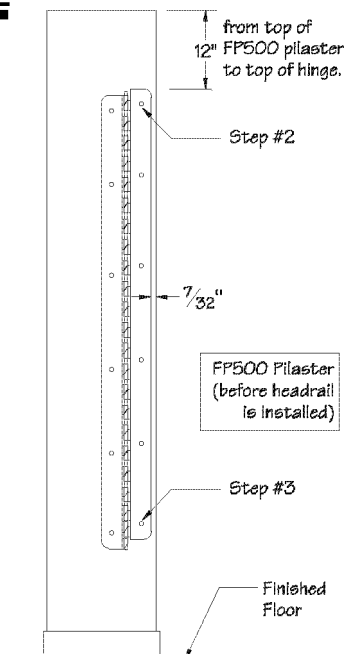

STEP 7C - ALUMINUM WRAPAROUND HINGES

- A. The top portion of the top hinge assembly and the bottom portion of the bottom hinge assembly will always attach to the door. The top hinge assembly will always have the beveled cam. The bottom hinge assembly is packaged with a small cardboard spacer between the 2 portions. Keep this cardboard spacer on the hinge (it will be removed at a later time). It is used to properly locate the bottom section so that the door can later be raised for emergency access.
- B. Position the top portion of the bottom assembly onto the pilaster measuring 18 7/8" AFF to the bottom of the leaf. Using the 1" flathead sheet metal screw provided, fasten through the side of the hinge into the side of the pilaster to hold the hinge in place. Drill 4 clearance holes through the pilaster using the 4 holes in the hinge as a template. Fasten the hinge in place with step bolts and barrel nuts through each of the holes.
- C. Repeat to install the bottom portion of the top assembly onto the pilaster measuring 59 3/4" AFF.
- D. Mount the top portion of the top assembly (with the beveled cam) onto the top half previously installed onto the pilaster. At this point the cam can be rotated to adjust the angle of the door in the rest position. 5- With the door set on 13 1/2" high blocking, position it into the top door hinge. Using 1" flathead sheet metal screw, fasten through the side of the hinge into the side of the door. Drill 4 clearance holes through the door using the 4 holes in the hinge as a template. Fasten in place with step bolts and barrel nuts through each hole. 6- Being certain that the cardboard spacer is still on the shaft of the bottom hinge (the half previously installed on the pilaster), slide the bottom portion of the bottom hinge assembly up the door so that it mates with the other half of the bottom hinge assembly. With this portion of the hinge pushed up all the way, mark its position. Remove this half of the hinge so that you can now remove the cardboard spacer. Then re-position this hinge half onto the door. Using the 1" flathead sheet metal screw provided, fasten through the side of the hinge into the side of the door to hold the hinge in place. Drill 4 clearance holes through the door using the 4 holes as a template. Fasten the hinge in place with step bolts and barrel nuts through each of the holes.

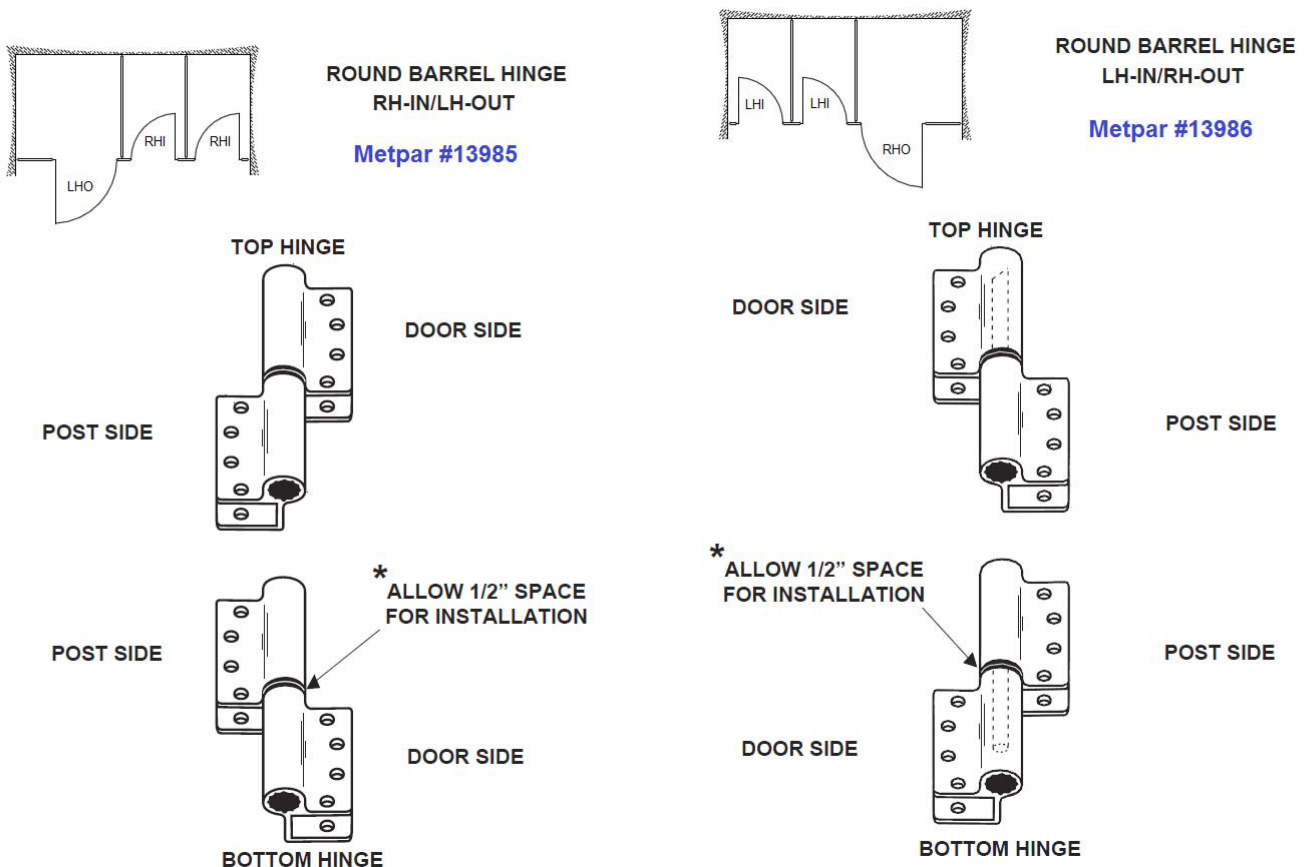

STEP 8 - SURFACE SLIDE LATCH INSTALLATION

- A. Locate the surface mounted slide latch at the desired elevation and fasten onto the inside of the door with sheet metal screws.
- B. Position the wrap-around style strike & keeper so that the bar of the slide latch will engage properly. Mount in place with thru-bolts. For outswing doors, the bar will engage behind the door strike. For inswing doors, the bar will engage into the keeper.
- C. For ADA accessibility, mount the strike & keeper so that half of the slide bar is above the keeper. See detail at right. This will allow you to lift the door and thereby lift the latch over the keeper thus providing emergency access.

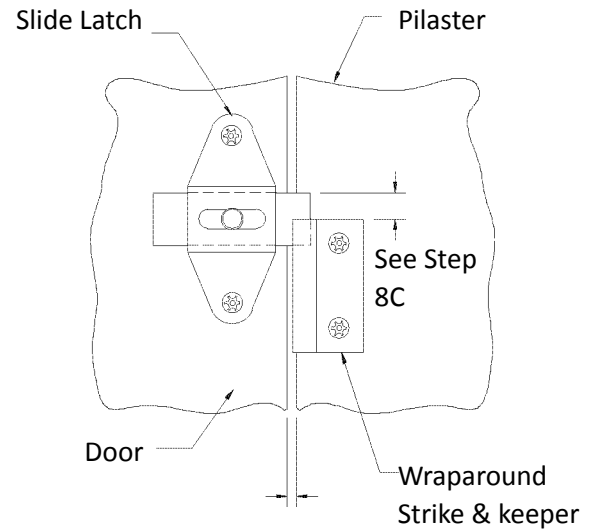

STEP 9 - CARE & MAINTENANCE

- A. All surfaces can be kept clean with water and a mild soap solution. Wipe all surfaces dry after cleaning.
- B. DO NOT use any caustic or acidic type cleansers.
- C. In high humidity areas, the rooms should be properly ventilated.
- D. The nylon door cams can be lubricated if necessary with a white lithium or equal water-proof lubricant.

STEP 10 - NEED HELP?

- A. In the unlikely event that you need further help, you have several resources. First, contact the Partition Stalls representative from which you purchased the materials. They are best equipped to assist you.
- B. Another quick and easy source of information is the Partition Stalls internet web site. Here you'll find a wealth of information, details, specifications, technical support and so much more! Our URL address is <http://www.partitionstalls.com> or send e-mail to info@partitionstalls.com
- C. You can also contact us by phone at 646-453-4564,