



**Partition  
Stalls**

# Phenolic Installation Manual



[info@partitionstalls.com](mailto:info@partitionstalls.com)  
646-453-4564

# Table of Contents

• Before you begin	Page 1
• Suggested tools	Page 1
• Partition Stalls Tips	Page 2
• Hardware nomenclature	Page 2
• Step 1-Layout	Page 3
• Step 2-Prepare Stiles	Page 3 - 4
• Step 3-Position Panel	Page 4
• Step 4-Attach Stiles	Pages 5 - 7
• Step 5-Secure stiles to panel	Page 8
• Step 6-Headrail & Panel fasten	Page 8
• Step 7-Install Door	Page 8
• Step 8-Care & Maintenance	Page 9
• Step 9-Need Help?	Page 9

## **Before you begin, note the following...**

- Caution, safety first! Be certain to have and use the proper safety gear.
- Structural support in the walls, floors and/or ceiling is not supplied by Partition Stalls. Verify that adequate blocking has been installed where necessary before you proceed.
- This installation manual should be used in conjunction with the layout drawings prepared by Partition Stalls. Refer to the layout drawings for further information such as: product style (ie: The Corinthian FP-500 Overhead Braced), stall width and depth, ceiling height (for ceiling hung or floor-to-ceiling), individual component sizes (ie: panels, stiles &/or doors), etc. You will need the layout drawings to determine the centerline markings for drilling locations. If you have "no peek" design, you MUST have the layout drawing which includes special notes to indicate the location for each individual pilaster and door.
- When the material is shipped to you, an Initial Release (packing list) is included. Be certain that all items you need have been ordered and shipped properly.

## **Suggested Tools...**

For your convenience, we recommend that you have the following tools:

Tape Measure, chalk line, pencil asking tape (to help you layout drilling locations), electric or battery operated drill, drill bits including torx pin head t27 bit, screwdriver (flathead and phillips head), center punch, plumb-bomb, level, hacksaw, hammer, shims, support blocks (12"high).

## Partition Stalls tips...

1. IMPORTANT... For stainless steel partitions with stainless steel sheet metal screws, it is strongly suggested that you pre-drill pilot holes. For #10 screws use a #28 drill for a .140" hole. For #14 screws use a #10 drill for a .193" hole.
2. Plan ahead... coordinate all of the materials and hardware for each specific layout. Study your layout drawings and evaluate any special conditions that may require custom size materials, unique hardware or special tools.
3. When you determine the centerline dimensions, refer to the stall depths shown on your layout drawings. For Powder Shield, Stainless Steel and Plastic Laminate pilasters, the centerline is 5/8 " less than the stall depth. Solid Phenolic pilasters are 3/8"less.
4. Read all of these instructions carefully and thoroughly. Reading this manual first will better prepare you for the entire installation.

## Hardware Nomenclature...

What does "p1" mean? What are all those little circles on my layout drawing? These indicate the hardware to be used at that location. Each one is an abbreviation for the bracket type. Each hardware package is marked with the same notation for easier identification.

- • P1 = One ear panel bracket
- P2 = Two ear panel bracket
- P3 = One ear alcove panel and post
- PF = "PF" Screen with panel and post
- WH = Wall hung urinal screen
- S1L = Stile one-ear long bracket (3" & up)
- S3L = Same as S1L but with 3 brackets
- S1LP = Stile one-ear bracket against panel
- S3M = Post one-ear mini bracket (3 per)
- EHR = End headrail brackets
- DB1 = Door bumper
- H -1 = Inswing door hardware
- H - 2 = Outswing door hardware
- H - 3 = Entry door hardware
- P-S-1 = Inswing Post to Stile Door Hardware (post on hinge side of door & stile on strike side)
- P-S-2 = Outswing Post to Stile Door Hardware (post on hinge side of door & stile on strike side)

## STEP 1 - LAYOUT

- Mark the centerline for the pilasters from the back wall. The centerline of the stile is  $\frac{3}{8}$ " less than overall stall depth shown. Measure out at each end of overall distance from first stall to last in line.
- Mark the centerline for all top and bottom wall brackets. Adjust if possible to locate in mortar joints. CAUTION: if doors use S/S surface hinges, you may need to raise or lower the wall brackets on 3" and 4" stiles to avoid any conflict with the door hinges.
- From side wall, measure along the centerline of the pilasters to locate the floor fasteners, to be located 1" from each end of each pilaster. FP stiles at 3" use only (1) floor mounting. FT and CH stiles at 3", 4" and 5" use only (1) mounting. All others use 2 mountings.
- Mark bracket holes to be drilled using brackets as templates. Pilaster brackets have wider space between the legs because a stile is thicker than a panel.
- Drill  $\frac{1}{4}$ " holes for wall brackets.
- Drill holes for floor fasteners,  $\frac{1}{4}$ " for FP500,  $\frac{3}{8}$ " for FT700.
- Secure wall brackets with #12 x 2  $\frac{1}{2}$ " screws.

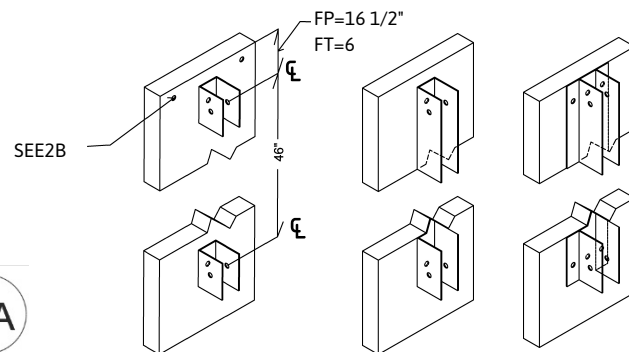
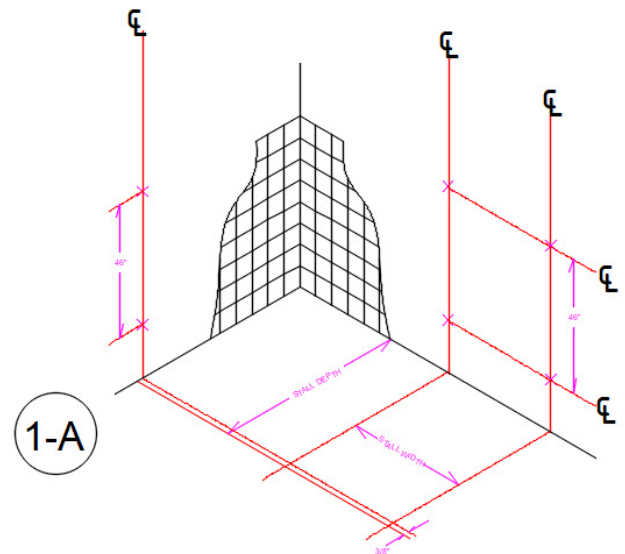

## PLEASE NOTE BEFORE INSTALLING



If the project calls for a "No-Peek" design where the gaps are concealed between each pilaster and door, the pilasters and doors will be supplied with a rabbeted edge so they overlap thus creating the "No-Peek" design.

The following designations are assigned to each pilaster to indicate which combination of rabbeted edges it requires. The notation is marked on the packing list to coincide with the layout drawings. Check each pilaster and compare to the designation noted on the layout drawings to ensure that you are using the correct pilaster in each location.



No rabbeted edge. Used for screens.



HLI-HRO or SLI-SRO  
HLI-SRO or SLI-HRO



HRO or SRO



HLO-HRI or SLO-SRI  
HLO-SRI or SLO-HRI



HLI or SLI

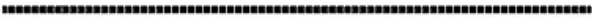

HRI or SRI



HLO-HRO, or SLO-SRO  
HLO-SRO or SLO-HRO



HLO or SLO



HLI-HRI, or SLI-SRI  
HLI-SRI or SLI-HRI

Stall panel at wall

## STEP 2 - PREPARE STILES

- A. Position the panel-to-pilaster brackets up against the back of the pilaster using the centerline dimensions. To locate the first hole, on FP500 and FT700 stiles measure downward. On CH700 stiles measure upward. Drill clearance holes through the pilaster and fasten in place with step bolts and barrel nuts provided.
- B. On FP500 stiles, drill 2 clearance holes through the pilaster at the top for headrail screws as shown in Detail 2-A.
- C. For FP500 stiles, extend the leveling bolt (jackstuds) to measure 80 1/2" from the top of the pilaster to the bottom of the leveling bolt or finished floor.
- D. Slide the stainless steel plinth (aka "shoe") onto the stile now before the stile is fastened to the floor.

## STEP 3 - POSITION PANEL

- A. Set the panel onto some type of support 12" high in position to hold the panel.
- B. Set the panel into the wall bracket but do not fasten the panel to the wall brackets yet.

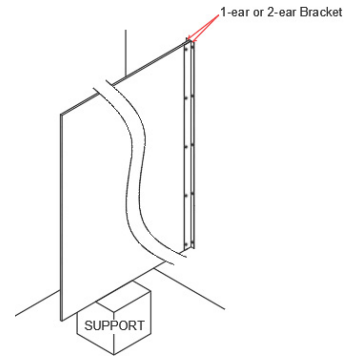

**3-A**

Pilaster at wall

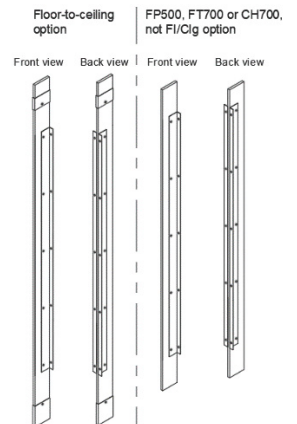

### STEP 3 - POSITION PANEL

- A. Place plastic anchors into the floor holes.
- B. Over each floor anchor place L-bracket assemble. Fasten into anchor with #12 x 1 1/2" screw.
- C. Place stile over L-Brackets and push panel into brackets installed behind pilaster. Fasten one 1/4"-20 screw through each L-Bracket along with a nut and washer.
- D. Plumb stile, place wedge at top rear between panel and wall.
- E. Fasten panel to brackets behind pilaster with thru-bolts provided.

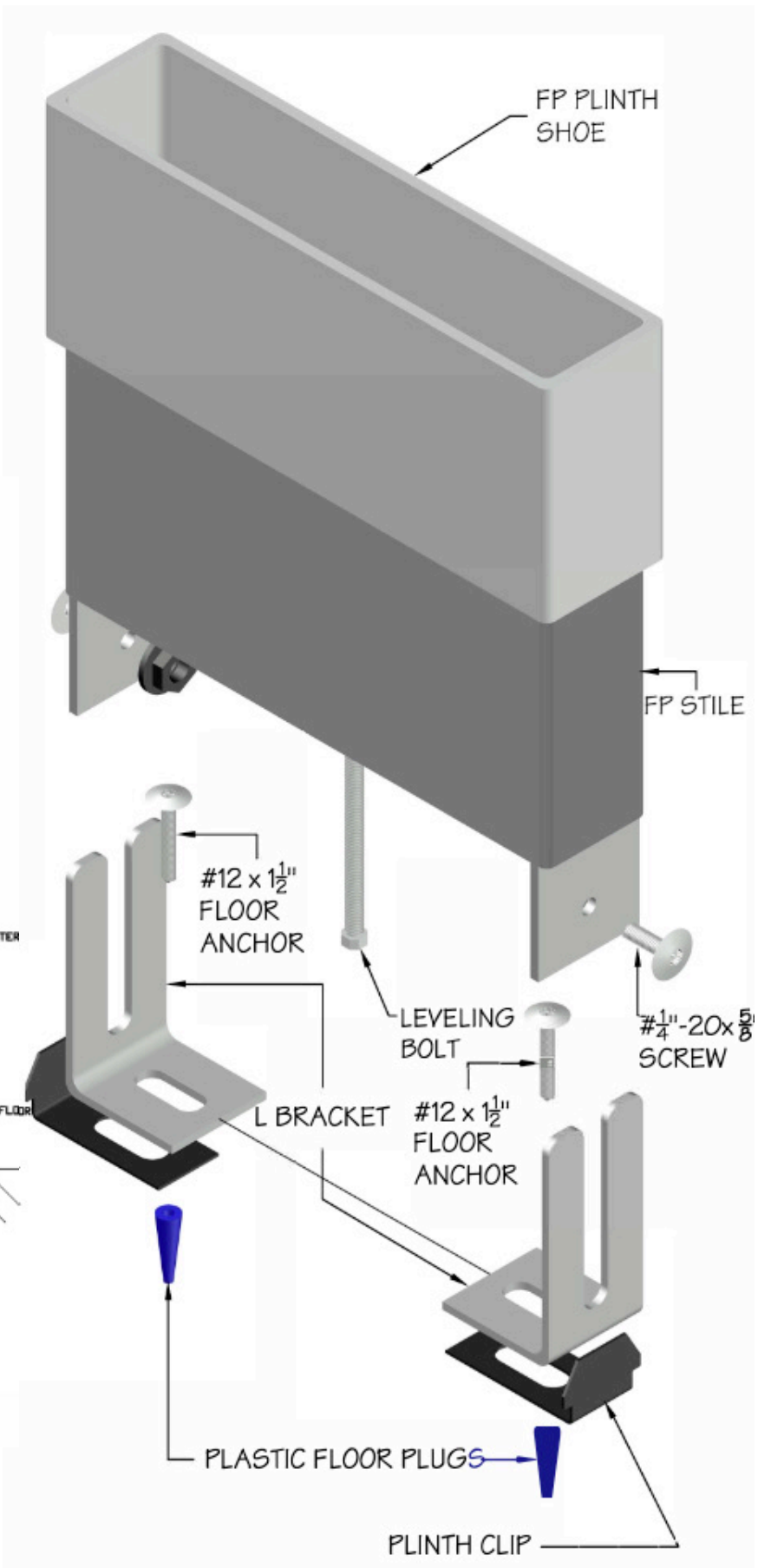
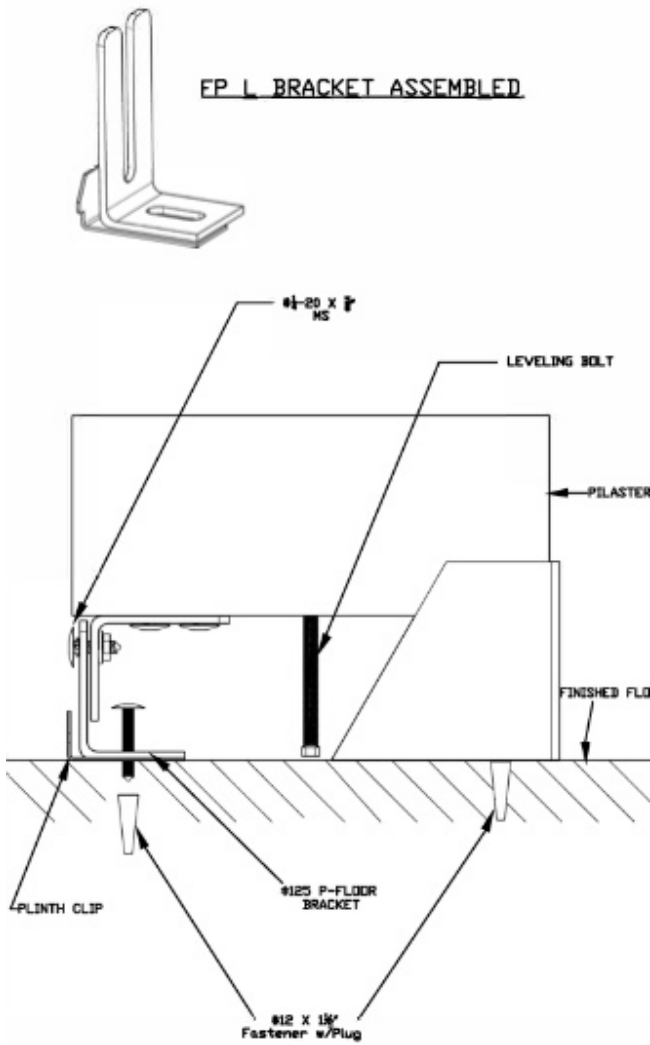

# STEP 4B - CH700 PILASTER ATTACHMENT

- A. When attaching each ceiling hung pilaster to overhead support, a 3/8-16 x 6" threaded rod is provided in a hardware kit (#15697). A longer 3/8" rod can be used if needed. Prep the pilaster by placing these items on the rod in order: one (1) hex nut, two (2) washer, one (1) hex nut. These will fit above & below the pilaster bracket as seen below in the "CH Rod Assembled" detail.
- B. Slide the rod onto the pilaster bracket, adjust the placement of the nuts and washer and hand-tighten against the bracket. Repeat for 2nd rod on pilaster if a 2nd rod exists.
- C. Put on another nut and washer on each rod which will be positioned underneath the overhead support. See detail below.
- D. Position the pilaster rods so they insert into the clearance holes in the overhead support. Then install another nut and washer on each rod above the overhead support. Hand-tighten.
- E. Adjust the position of the pilaster height so that the pilasters and panels align at the bottom. Adjust position of nuts and washer as needed to plumb the pilaster. Then fully tighten all nuts to lock in position.
- F. If you have not done so yet, now slide the pilaster plinth (aka "shoe") onto the pilaster.

- G. Making sure the panel is plumb & level, position the panel inside the front brackets between the panel and pilaster. Fasten the panel to these brackets with thru-bolts provided. Then remove the panel support.
- H. Attach the pilaster plinth to the pilaster with a sheet metal fastener.

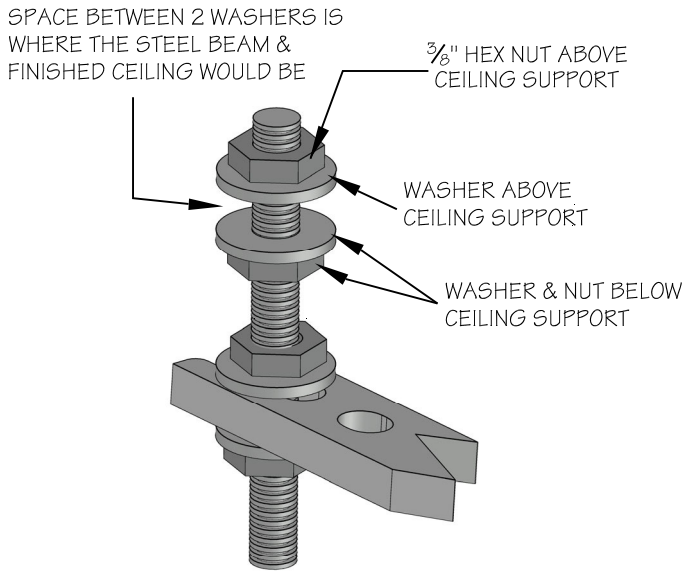

**CH ROD ASSEMBLED**

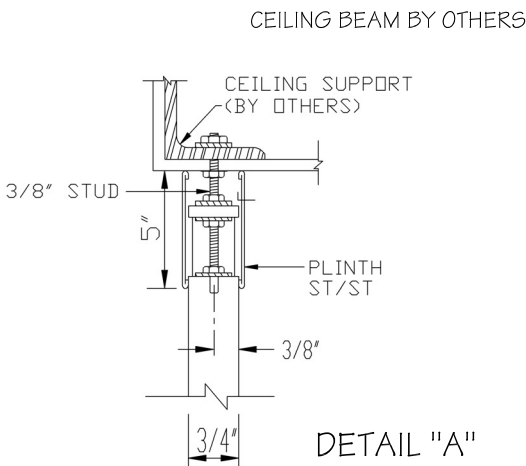

**DETAIL 'A'**

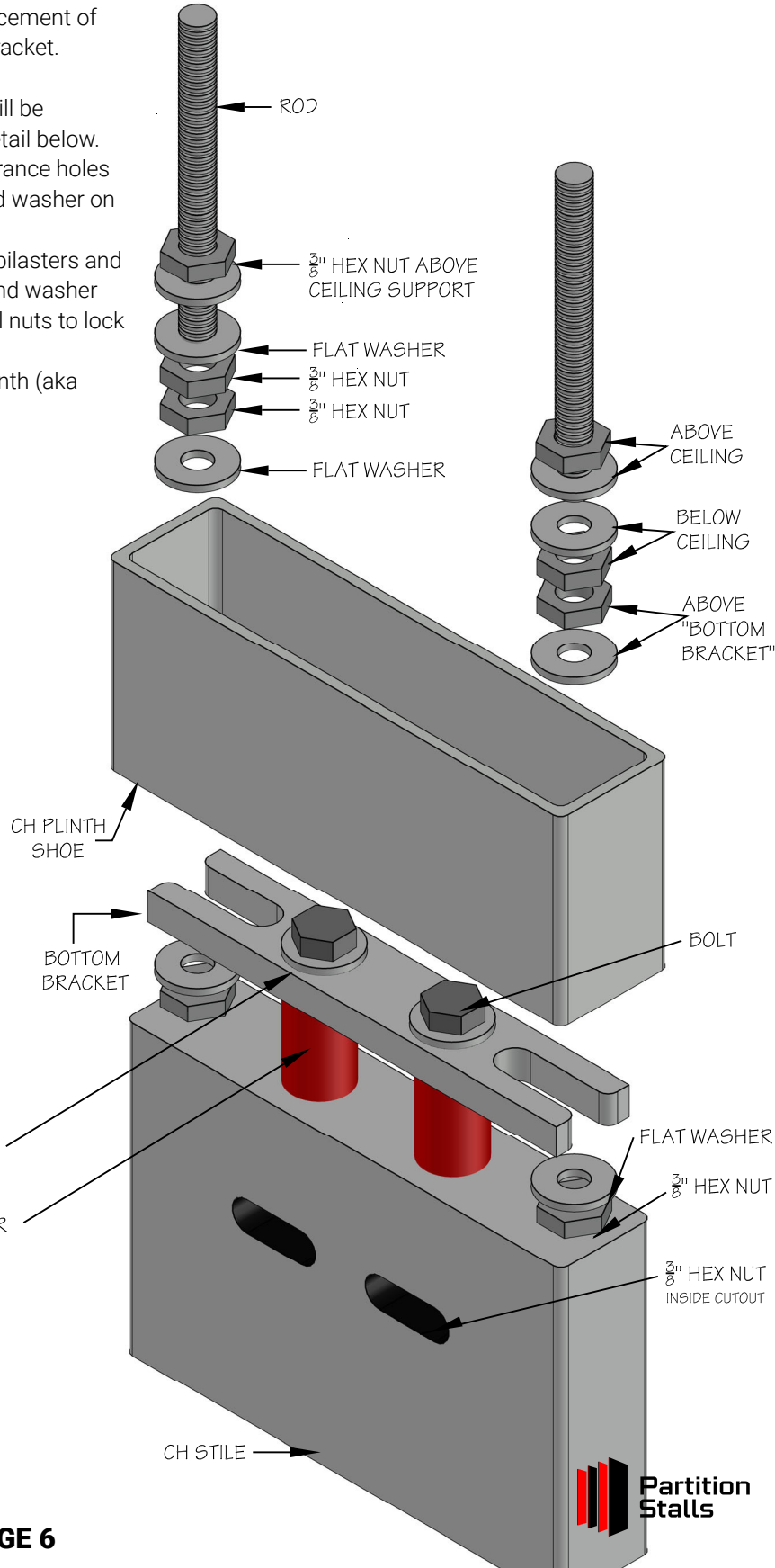

## STEP 4C - FT700 PILASTER ATTACHMENT

- A. Place expansion shield (1) into floor holes.
- B. Screw 3/8" rods (2) into expansion shields (1).
- C. Place a flat washer (3), flat washer (4) and hex nut (5) on the rod (2) and tighten to expand the shield.
- D. Place one hex nut (6) and then one flat washer (7) onto each rod (2). Lower it near the bottom. These will be raised later and tightened underneath the stile bottom (12).
- E. Slide the plinth (11) onto the stile (13) and move upward out of the way for now.
- F. Position and lower the stile (13) onto the rods (2).
- G. Place one flat washer (9) and hex nut (10) onto each rod (2) and tighten over the bottom stile.
- H. Top of the stile and panel should align. Position panel into brackets installed behind stile.
- I. Plumb the stiles and place a wedge between the top rear of the panel and wall. Repeat the panel and stile of necessary. DO NOT fasten the panel in place yet and DO NOT remove the panel support blocks at the floor.
- J. Adjustments can be made to stile (13) to correct height plumb level by raising/lowering the hex nuts (6 & 10) above/below the FT Clamp.

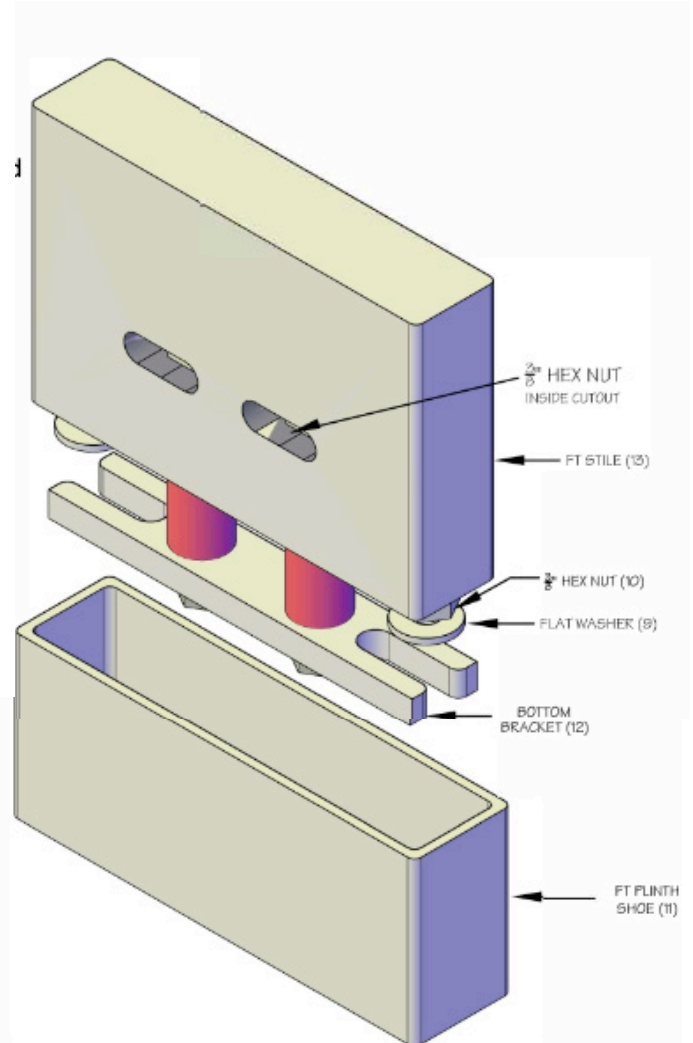

FT ROD ASSEMBLED

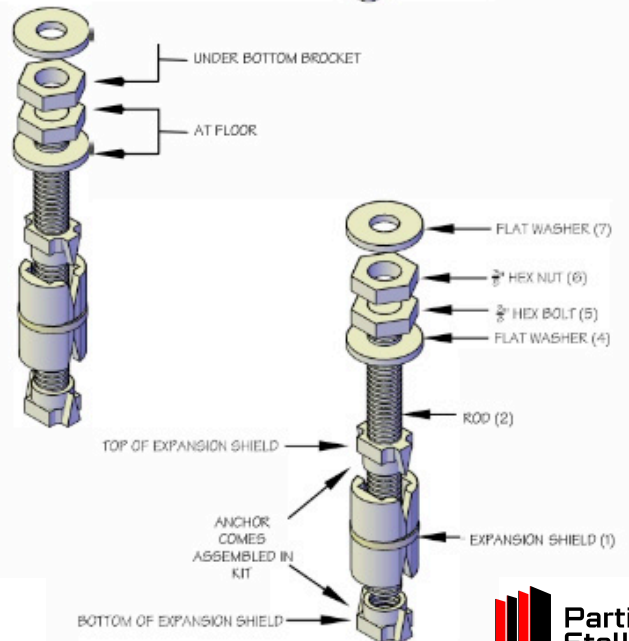
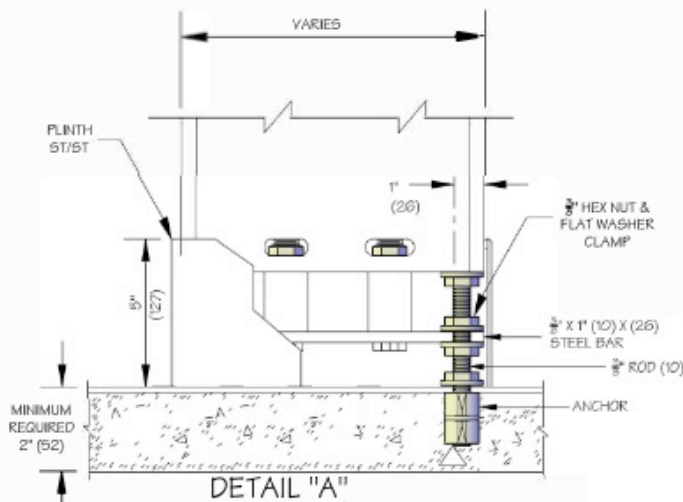

## **STEP 5 - SECURING STILES TO PANELS**

- A. Stiles must be both plumb and level. Headrail may be used as an aide in this process by temporarily setting them in position. (DO NOT fasten at this time).
- B. Plumb stile and adjust elevation. Fasten stile to panel using step bolts & barrel nuts.
- C. By adjusting stile L-brackets on FP500, the proper door opening and stile elevation can be attained and set in position by tightening screws.

## **STEP 6 - HEADRAIL & PANEL FASTENING**

- A. Place headrail on top of stiles. Plumb while setting door gaps, and fasten headrail to stiles using a step bolts & barrel nuts.
- B. Fasten panel to wall brackets.
- C. Cut excess headrail 1/8" to 1/4" past end of stile. Insert headrail end plug.
- D. To ensure rigidity, install rectangular end-headrail for depth of last stall by securing with brackets at back of stile and also at the back wall. Align over the end panel.

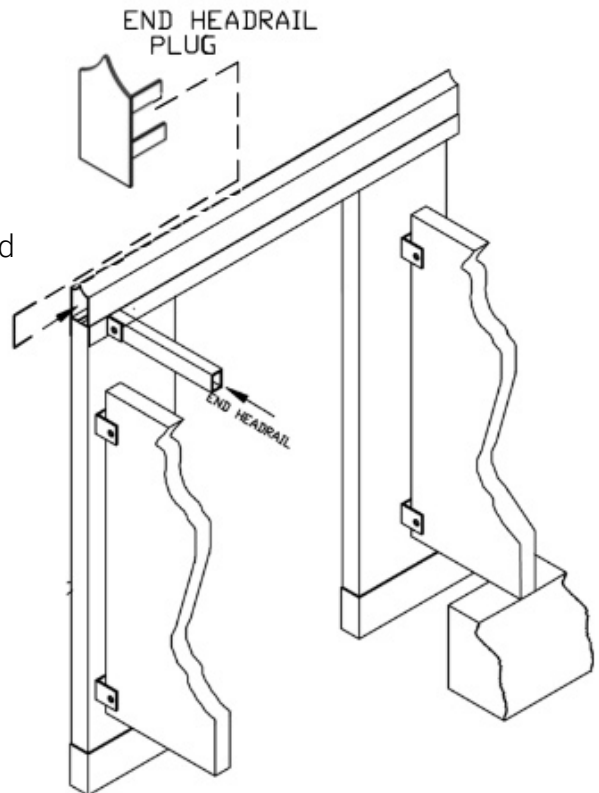

## **STEP 7 - INSTALL DOOR**

- A. Fasten top and bottom hinge brackets to the pilaster. (Make sure that hinge bracket with the beveled cam is located at upper connection). At this point the cam can be rotated to adjust angle of the door the in the rest position.
- B. Fasten top hinge bracket only to top of door.
- C. Mount the door by placing the top door hinge on top of the top pilaster hinge.
- D. Slide bottom hinge of door into bottom hinge of pilaster and fasten bracket to door.
- E. Position the slide latch on the inside face of the door using the 2 holes to mark their position on the door. Drill clearance holes through the door. Install the slide latch using step bolt and barrel nuts.
- F. Position the strike & keeper on the pilaster aligning it with the slide latch so that the latch bar engages into the S&K. Mark the holes from the S&K and drill clearance holes through the pilaster. Install the S&K with step bolts and barrel nuts.
- G. Position the coat hook & bumper as well as the door pull on the door. Using the holes, mark their position and drill clearance holes. Then install using step bolts and barrel nuts.

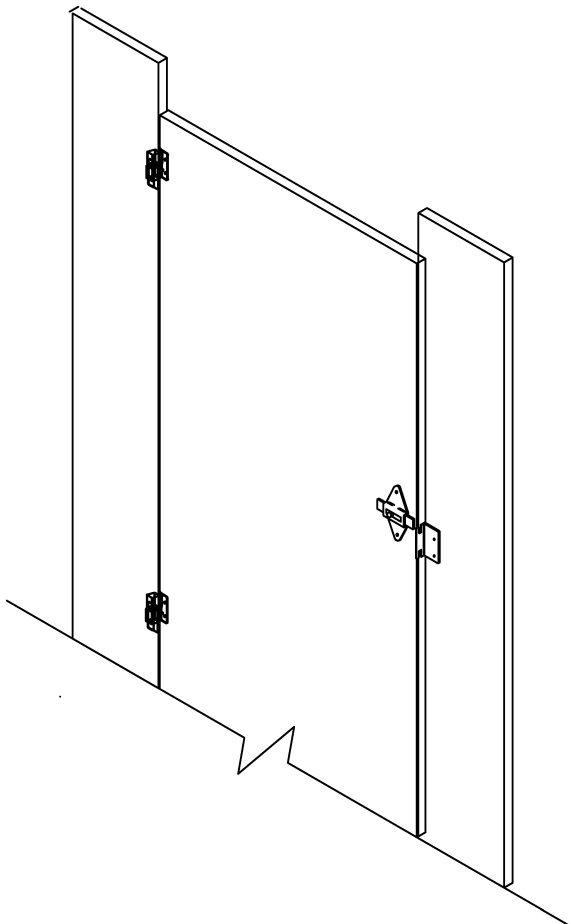

## CARE AND MAINTENANCE OF TOILET PARTITIONS

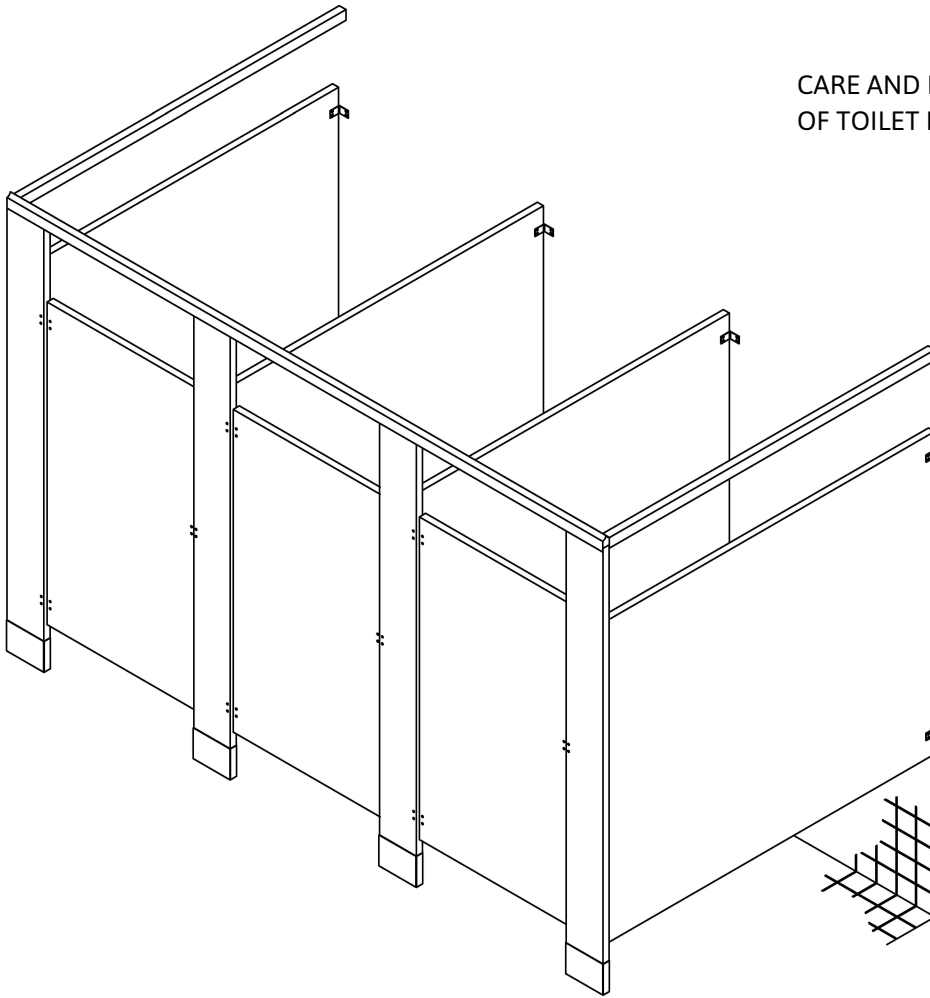

### **STEP 8 - CARE AND MAINTENANCE**

- A. All surfaces must be kept clean with water and mild soap solution.
- B. Water left on units for extended periods of time will damage surface. The finish must be wiped dry following cleaning.
- C. In high humidity areas, the rooms must be properly ventilated.
- D. For maximum protection, periodic applications of good quality car wax will be beneficial for powder shield materials.

### **STEP 9 - NEED HELP?**

- A. In the unlikely event that you need further help, you have several resources. First, contact the Partition Stalls representative from which you purchased the materials. They are best equipped to assist you since they are already familiar with your project and experienced with Partition Stalls products.
- B. Another quick and easy source of information is the Partition Stalls web site. Here you'll find a cornucopia of information, details specifications and technical support and so much more. Our URL address is <http://www.PartitionStalls.com> or send e-mail to [info@partitionstalls.com](mailto:info@partitionstalls.com)
- C. You can also contact us by phone at 646-453-4564.